

SERVICE MANUAL

HRG14xxS1P



This is a safety alert symbol and should never be ignored. When you see this symbol on labels or in manuals, be alert to the potential for personal injury or death.

Table of Contents

Technical Specifications - HRG14xxS1P2

Parts Arrangement.....6

General Information.....7

Operating Gauge Set and Service Valves7

Installation8

Refrigeration Piping10

Electrical Wiring.....18

Operation.....19

Maintenance21

Homeowner Information21

Start-Up26

Start-Up and Performance Checklist.....32



CAUTION

As with any mechanical equipment, contact with sharp sheet metal edges can result in personal injury. Take care while handling this equipment and wear gloves and protective clothing.

WARNING



Electric shock hazard.

Can cause injury or death. Before attempting to perform any service or maintenance, turn the electrical power to unit OFF at disconnect switch(es). Unit may have multiple power supplies.

WARNING

Improper installation, adjustment, alteration, service or maintenance can cause property damage, personal injury or loss of life. Installation and service must be performed by a licensed professional HVAC installer (or equivalent), service agency or the gas supplier.



(P) 508090-01

Technical Specifications - HRG14

MODEL NUMBER GUIDE

H	R	G	14	24	S	1	P
Heat Pump	Residential Split	'Green' Gas R-410A	SEER 14	Capacity BTUH x 1000	S = Scroll Compressor	Power 1 = 208/230-1-60	Series/Revision

PHYSICAL AND ELECTRICAL DATA

Model	Voltage/Hz/Phase	Voltage Range	Min. Circuit Amp.	Max. Over Current Device (amps)	Compressor		Outdoor Fan Motor		
					Rated Load (amps)	Locked Rotor (amps)	Full Load (amps)	Rated HP	Nom. RPM
HRG1418S1P	208-230/60/1	197-253	12.3	20	9.0	48	1.1	1/6	825
HRG1424S1P	208-230/60/1	197-253	17.9	30	13.4	58	1.1	1/6	825
HRG1430S1P	208-230/60/1	197-253	17.1	25	12.8	64	1.1	1/6	825
HRG1436S1P	208-230/60/1	197-253	18.7	30	14.1	77	1.1	1/6	825
HRG1442S1P	208-230/60/1	197-253	25.8	45	19.2	123.9	1.8	1/4	825
HRG1448S1P	208-230/60/1	197-253	26.2	45	19.6	130	1.8	1/4	825
HRG1460S1P	208-230/60/1	197-253	29.6	50	22.2	127.9	1.8	1/4	825

UNIT DIMENSIONS (IN.)

Model	Dimensions (in.)			Shipping Weight (lbs.)
	A - Width	B - Depth	C - Height	
HRG1418S1P	28.25	28.25	43.25	182
HRG1424S1P	28.25	28.25	43.25	184
HRG1430S1P	28.25	28.25	43.25	183
HRG1436S1P	28.25	28.25	37.25	199
HRG1442S1P	32.25	32.25	37.25	249
HRG1448S1P	32.25	32.25	37.25	252
HRG1460S1P	32.25	32.25	43.25	270

Note:
 Dimensions listed are unit sizes w/o packaging
 Weights listed are unit weights with packaging

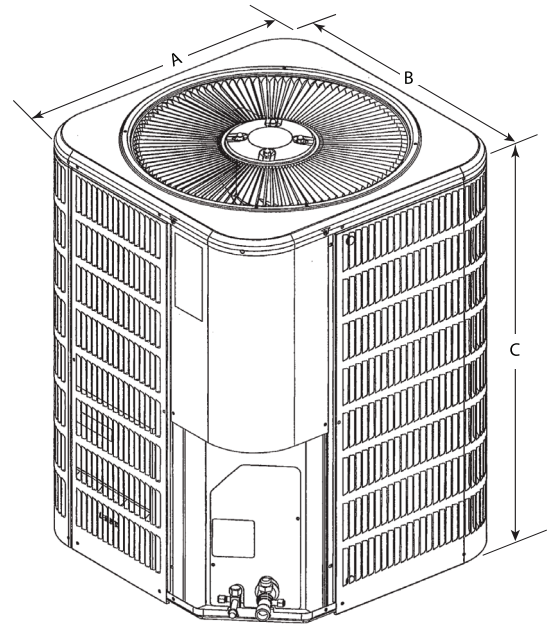

SOUND RATINGS

Model	Sound Power ¹	Estimated Sound Pressure (dBA) ²		
		Approximate Distance ³		
		3.3 Feet (1 Meter)	6.6 Feet (2 Meters)	9.8 Feet (3 Meters)
HRG1418S1P	76	68	62	58
HRG1424S1P	76	68	62	58
HRG1430S1P	76	68	62	58
HRG1436S1P	76	68	62	58
HRG1442S1P	79	71	65	61
HRG1448S1P	80	72	66	62
HRG1460S1P	80	72	66	62

1. Rated in accordance with AHRI standard 270 (2015). AHRI Standard 270 establishes a method of rating outdoor unitary equipment in terms of Sound Power.

2. Rated in accordance with AHRI standard 275 (2010). AHRI Standard 275 provides the calculations for estimating the A-Weighted Sound Pressure at a given distance from the equipment. That is a more useful number because that is what humans will hear.

3. Based only on distance factor; other factors may change this value such as:

- Unit location (reflective surfaces adjacent to the unit)
- Barrier shielding sources
- Sound path/elevation
- Outside noise sources

ACCESSORIES

System Accessory	Where Used	Kit Number	Purpose
Liquid Line Solenoid	All models	60M52	Prevents liquid migration to the compressor especially for high liquid riser applications
Low Ambient HP Units (cooling operation)	All models	54M89	Enables cooling demand down to 30 °F. Will require freeze stat, CC heater and TXV
Mild Ambient (heating operation)	All models	11B97	Enables heating demand above 60 °F ambient
Cold Weather	Control Board Integrated Feature		To allow unit to operate in very low ambient conditions
Fossil Fuel Kit (Heat Pump Only)	All models	1.841185	Required for furnace with heat pump installations
Hard Start	24 & 36	10J42	Scroll compressors usually do not require hard start; maybe needed for utility brown-out or low voltage areas
	48 & 60	81J69	
Crankcase Heater	18, 24, 30	93M04	Prevents liquid migration to compressor in cold weather
	36, 42, 48, 60	Factory Installed	
Sound Cover	18, 24, 30, 36	14W00	Lowers compressor sound level
	42, 48, 60	14W01	
Loss of Charge Kit	Factory Installed		Protects the compressor if refrigerant charge is too low
Additional System Accessories (indoor section)			
TXV Kit	18, 24, 30	H4TXV01	TXVs provide superior refrigerant flow control, comfort and efficiency compared to pistons
	36, 42, 48	H4TXV02	
	60	H4TXV03	
Outdoor Thermostat - Electric Heat	All models	10Z23	Prevents electric heat operation above specific ambient conditions
Single Point Power Supply	All models	21H39	Provide single power source in one junction box
Auxiliary Blower Relay	All models	85W66	Maybe required to select multiple indoor blower speeds

FAN BLADE

Model	Diameter (in.)	# of Blades	Pitch	Part #
HRG1418S1P	22	3	20	82W58
HRG1424S1P	22	3	20	82W58
HRG1430S1P	22	3	26	43W37
HRG1436S1P	22	3	28	16L95
HRG1442S1P	26	4	22	21W10
HRG1448S1P	26	4	22	21W10
HRG1460S1P	26	4	22	21W10

REFRIGERATION DATA

Model	Factory Refrig. Charge (Oz.)*	TXV	Refrigerant Line Size		Outdoor Unit Connection		Indoor Unit Connection	
			Suction	Liquid	Suction	Liquid	Suction	Liquid
HRG1418S1P	112	H4TXV01	3/4	3/8	3/4	3/8	3/4	3/8
HRG1424S1P	115	H4TXV01	3/4	3/8	3/4	3/8	3/4	3/8
HRG1430S1P	115	H4TXV01	3/4	3/8	3/4	3/8	3/4	3/8
HRG1436S1P	161	H4TXV02	7/8	3/8	7/8	3/8	3/4	3/8
HRG1442S1P	171	H4TXV02	7/8	3/8	7/8	3/8	7/8	3/8
HRG1448S1P	171	H4TXV02	7/8	3/8	7/8	3/8	7/8	3/8
HRG1460S1P	193	H4TXV03	1 1/8	3/8	7/8	3/8	7/8	3/8

* Factory charged for 15 feet of line set; adjust per installation instructions.
Refrigerant charge also varies with indoor unit; Refer to refrigerant charge label

PERFORMANCE WITH COILS, AIR HANDLERS AND FURNACES

Outdoor Model	Indoor Model	Cooling				Heating		
		Evap. Coil Air Handlers ¹	SEER	EER	AHRI Capacity ²	AHRI Reference Numbers	HSPF	47°
	Btuh							Btuh
HRG1418S1P	HCG24V1P	15.5	12.5	18,000	203216916	8.5	17,300	10,600
	HMG24F1P	14.25	12.2	18,000	203216945	8.2	17,600	11,000
	HMG24X1P	16	13	18,000	203216950	8.5	17,200	10,600
HRG1424S1P	HCG24V1P	15.1	12.5	24,000	203216919	8.5	21,600	13,800
	HCG30V1P	16	13	24,000	203216922	9	19,200	13,500
	HMG24F1P	14	12	23,800	203216947	8.2	22,200	14,300
	HMG24X1P	15.5	12.5	24,000	203216953	8.5	21,600	13,600
	HMG30F1P	14.5	12.5	23,800	203216956	8.5	19,600	13,900
HRG1430S1P	HCG30V1P	15.1	12.5	30,000	203216924	8.5	26,400	16,900
	HCG36V1P	15.5	12.5	30,000	203216927	9	27,000	17,400
	HMG30F1P	14	11.5	29,600	203216959	8.5	27,000	17,500
	HMG30X1P	15.5	12.5	30,000	203216966	8.5	26,200	16,800
	HMG36F1P	14.5	12.2	30,000	203216969	8.5	27,400	17,800
	HMG36X1P	16	13	30,000	203216976	9	26,800	17,100
36	HMG36F1P	14	12	33,400	203216972	8.2	31,200	20,000
	HMG36X1P	15	12.5	33,800	203216989	8.2	30,800	19,500
HRG1442S1P	HCG42V1P	15	12.5	41,500	203216930	8.5	39,000	25,800
	HCG48V1P	15.5	12.5	42,000	203216934	8.5	39,000	25,600
	HMG42F1P	14	12	40,500	203216993	8.2	39,500	26,200
	HMG42X1P	15	12.5	41,000	203216996	8.2	39,000	25,600
	HMG48F1P	15.1	12.5	42,000	203217000	8.5	39,000	25,800
	HMG48X1P	15.5	12.5	42,000	203217005	8.2	39,000	25,600
HRG1448S1P	HCG48V1P	14.5	12.2	48,000	203216936	8.2	46,000	28,600
	HCG60V1P	15.1	12.5	48,000	203216939	8.5	42,000	27,800
	HMG48F1P	14	11.5	47,500	203217002	8.2	46,000	29,000
	HMG48X1P	14	11.5	47,500	203217008	8.2	46,000	28,800
	HMG60F1P	15.1	12.5	48,000	203217011	8.5	42,000	27,600
	HMG60X1P	15.5	12.5	48,000	203217018	8.5	42,000	27,600
HRG1460S1P	HCG60V1P	14	12	56,500	203216942	8.2	55,000	35,800
	HMG60F1P	14.25	12	56,500	203217014	8.5	54,500	35,400
	HMG60X1P	14.25	12.2	56,500	203217021	8.2	54,500	35,400

Note: ¹ A blower time delay relay is required to achieve AHRI rating. This feature is standard on all furnaces and AH products

² Certified in accordance with Unitary Air Conditioner Certification Program, which is based on AHRI Standard 210/240

Parts Arrangement

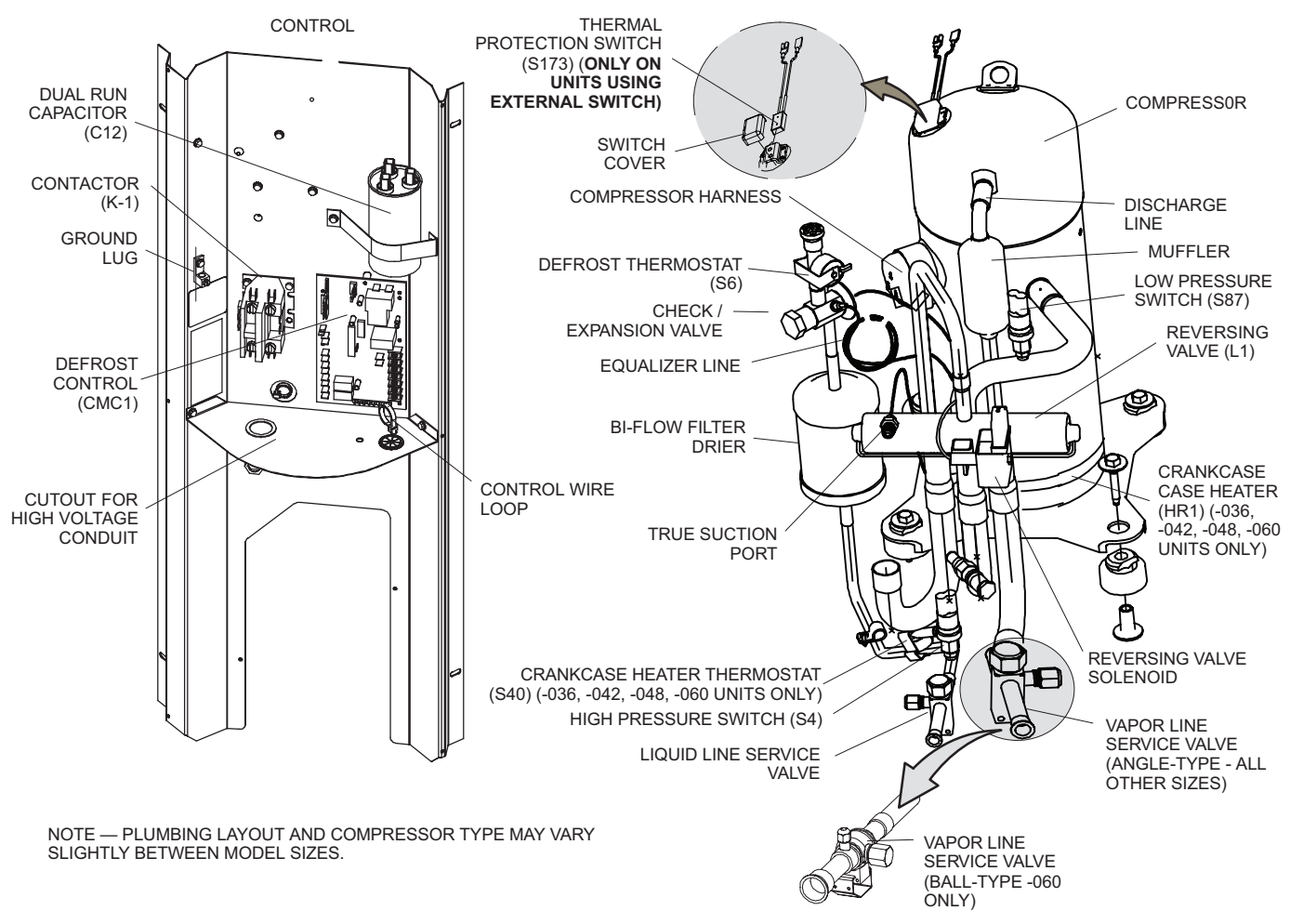

General Information

These instructions are intended as a general guide and do not supersede national or local codes in any way. Consult authorities having jurisdiction before installation.

Operating Gauge Set and Service Valves

CAUTION

As with any mechanical equipment, contact with sharp sheet metal edges can result in personal injury. Take care while handling this equipment and wear gloves and protective clothing.

Torque Requirements

When servicing or repairing heating, ventilating, and air conditioning components, ensure the fasteners are appropriately tightened. Table 1 lists torque values for fasteners.

IMPORTANT

Only use Allen wrenches of sufficient hardness (50Rc - Rockwell Harness Scale minimum). Fully insert the wrench into the valve stem recess.

Service valve stems are factory-torqued (from 9 ft-lbs for small valves, to 25 ft-lbs for large valves) to prevent refrigerant loss during shipping and handling. Using an Allen wrench rated at less than 50Rc risks rounding or breaking off the wrench, or stripping the valve stem recess.

IMPORTANT

To prevent stripping of the various caps used, the appropriately sized wrench should be used and fitted snugly over the cap before tightening.

When servicing or repairing HVAC components, ensure the fasteners are appropriately tightened. Table 1 provides torque values for fasteners.

Parts	Recommended Torque	
Service valve cap	8 ft.-lb.	11 NM
Sheet metal screws	16 ft.-lb.	2 NM
Machine screws #10	28 ft.-lb.	3 NM
Compressor bolts	90 ft.-lb.	10 NM
Gauge port seal cap	8 ft.-lb.	11 NM

Table 1. Torque Requirements

Using Manifold Gauge Set

When checking the system charge, only use a manifold gauge set that features low loss anti-blow back fittings.

Manifold gauge set used with HFC-410A refrigerant systems must be capable of handling the higher system operating pressures. The gauges should be rated for use with pressures of 0 - 800 psig on the high side and a low side of 30" vacuum to 250 psig with dampened speed to 500 psi. Gauge hoses must be rated for use at up to 800 psig of pressure with a 4000 psig burst rating.

Operating Service Valves

The liquid and vapor line service valves are used for removing refrigerant, flushing, leak testing, evacuating, checking charge and charging.

Liquid and Suction Line Service Valves

The liquid line and suction line service valves (see Figure 1) and service ports are used for leak testing, evacuation, charging, and checking charge.

Each valve is equipped with a service port which has a factory-installed Schrader valve. A service port cap protects the Schrader valve from contamination and serves as the primary leak seal.

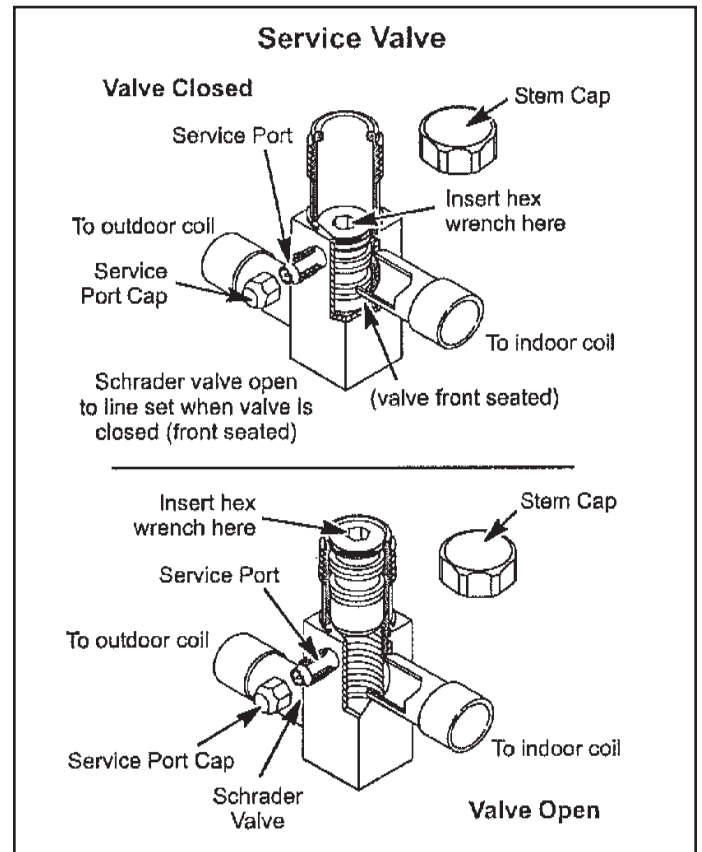

Figure 1.

To Access the Schrader Port:

1. Remove the service port cap with an adjustable wrench.
2. Connect gauge to the service port.
3. When testing is completed, replace service port cap. Tighten finger tight, then an additional 1/6 turn.

To Open Liquid or Suction Line Service Valve:

1. Remove stem cap with an adjustable wrench.
2. Use service wrench with a hex-head extension to back the stem out counterclockwise as far as it will go. Use a 3/16" hex head extension for liquid line service valves and a 5/16" extension for suction line service valves.
3. Replace the stem cap. Tighten finger tight, then tighten an additional 1/6 turn.

To Close Liquid or Suction Line Service Valve:

1. Remove the stem cap with an adjustable wrench.
2. Use a service wrench with a hex-head extension to turn the stem clockwise to seat the valve. Tighten firmly.
3. Replace the stem cap. Tighten finger tight, then tighten an additional 1/6 turn.

Suction Line (Ball Type) Service Valve

Suction line (ball type) service valves function the same way as the other valves; the difference is in the construction (see Figure 2).

The ball valve is equipped with a service port with a factory-installed Schrader valve. A service port cap protects the Schrader valve from contamination and serves as the primary seal.

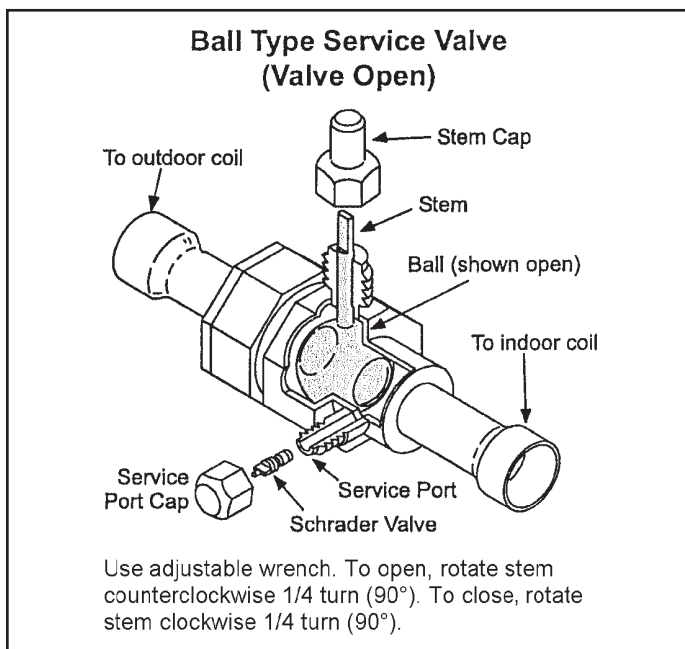

Figure 2.

Installation

NOTE: In some cases, noise in the living area has been traced to gas pulsations from improper installation of equipment.

- Locate unit away from windows, patios, decks, etc. where unit operation sounds may disturb customer.
- Leave some slack between structure and unit to absorb vibration.
- Place a sound-absorbing material, such as Isomode, under the unit if it will be installed in a location or position that will transmit sound or vibration to the living area or adjacent buildings.
- Install the unit high enough above the ground or roof to allow adequate drainage of defrost water and prevent ice buildup.

- In heavy snow areas, do not locate the unit where drifting snow will occur. The unit base should be elevated above the depth of average snows.

NOTE: Elevation of the unit may be accomplished by constructing a frame using suitable materials. If a support frame is constructed, it must not block drain holes in unit base.

- When installed in areas where low ambient temperatures exist, locate unit so winter prevailing winds do not blow directly into outdoor coil.
- Locate unit away from overhanging roof lines which would allow water or ice to drop on, or in front of, coil or into unit.

When outdoor unit is connected to factory-approved indoor unit, outdoor unit contains system refrigerant charge for operation with matching indoor unit when connected by 15 ft. of field-supplied tubing. For proper unit operation, check refrigerant charge using charging information located on control box cover.

Outdoor Section

Zoning ordinances may govern the minimum distance the condensing unit can be installed from the property line.

Install on a Solid, Level Mounting Pad

The outdoor section is to be installed on a solid foundation. This foundation should extend a minimum of 2" (inches) beyond the sides of the outdoor section. To reduce the possibility of noise transmission, the foundation slab should NOT be in contact with or be an integral part of the building foundation. See Figure 3.

If conditions or local codes require the unit be attached to pad or mounting frame, tie down bolts should be used and secured to unit base pan.

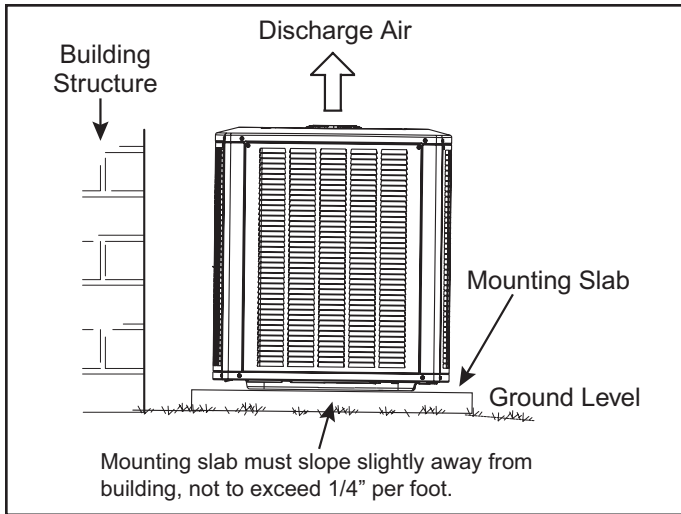

Figure 3. Slab Mounting

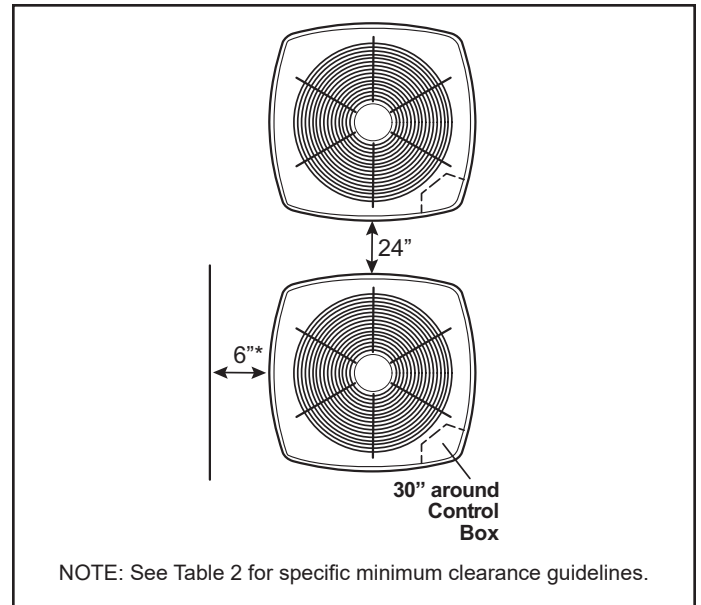

Figure 4.

Elevate Unit

⚠ CAUTION

Accumulation of water and ice in base pan may cause equipment damage.

Elevate unit per local climate and code requirements to provide clearance above estimated snowfall level and ensure adequate drainage of unit. Use snow stand in areas where prolonged freezing temperatures are encountered.

If conditions or local codes require the unit be attached to pad or mounting frame, tie down bolts should be used and fastened through knockouts provided in unit base pan.

Clearance Requirements

When installing, allow sufficient space for airflow clearance, wiring, refrigerant piping, and service. For proper airflow, quiet operation and maximum efficiency. Position so water, snow, or ice from roof or eaves cannot fall directly on unit. Refer to Table 2 for installation clearances.

Location	Minimum Clearance
Service box	30"
Top of unit*	48"
Between units	24"
Against wall	6"

* Maximum soffit overhang is 36".
NOTE: At least one side should be unobstructed by a wall or other barrier.

Table 2. Clearances

DO LOCATE THE UNIT:

- With proper clearances on sides and top of unit
- On a solid, level foundation or pad (unit must be level to within $\pm 1/4$ in./ft. per compressor manufacturer specifications)
- To minimize refrigerant line lengths

DO NOT LOCATE THE UNIT:

- On brick, concrete blocks or unstable surfaces
- Near clothes dryer exhaust vents
- Near sleeping area or near windows
- Under eaves where water, snow or ice can fall directly on the unit
- With clearance less than 2 ft. from a second unit
- With clearance less than 4 ft. on top of unit

Operating Ambient

The minimum outdoor operating ambient in cooling mode is 55°F, and the maximum outdoor operating ambient in cooling mode is 125°F. The maximum outdoor operating ambient in heating mode is 66°F.

Rooftop Installations

Install unit at a minimum of 6" above surface of the roof to avoid ice buildup around the unit. Locate the unit above a load bearing wall or area of the roof that can adequately support the unit. Consult local codes for rooftop applications.

If unit cannot be mounted away from prevailing winds, a wind barrier should be constructed. Due to variation in installation applications, size and locate barrier according to the best judgment of the installer.

Refrigeration Piping

Use only refrigerant grade copper tubes.

- Split systems may be installed with up to 50 feet of line set (no more than 20 feet vertical) without special consideration (see long line set guidelines).
- Ensure that vapor and liquid tube diameters are appropriate to capacity of unit.
- Run refrigerant tubes as directly as possible by avoiding unnecessary turns and bends.
- When passing refrigerant tubes through the wall, seal opening with RTV or other silicon-based caulk.
- Avoid direct tubing contact with water pipes, duct work, floor joists, wall studs, floors, walls, and any structure.
- Do not suspend refrigerant tubing from joists and studs with a rigid wire or strap that comes in direct contact with tubing.
- Ensure that tubing insulation is pliable and completely surrounds vapor tube.

It is important that no tubing be cut or seals broken until you are ready to actually make connections to the evaporator and to the condenser section. DO NOT remove rubber plugs or copper caps from the tube ends until ready to make connections at evaporator and condenser. Under no circumstances leave the lines open to the atmosphere for any period of time, if so unit requires additional evacuation to remove moisture.

Capacity	Liquid		Vapor	
	Connections Dia.	Tube Dia.	Connections Dia.	Tube Dia.
-018	3/8"	3/8"	3/4"	3/4"
-024	3/8"	3/8"	3/4"	3/4"
-030	3/8"	3/8"	3/4"	3/4"
-036	3/8"	3/8"	7/8"	7/8"
-042	3/8"	3/8"	7/8"	7/8"
-048	3/8"	3/8"	7/8"	7/8"
-060	3/8"	3/8"	7/8"	*1-1/8"

* Field supplied 7/8 x 1-1/8 connector required on both ends of vapor tubing.

Table 3. Recommended Liquid & Vapor Tube Diameters (in.)

Be extra careful with sharp bends. Tubing can “kink” very easily, and if this occurs, the entire tube length will have to be replaced. Extra care at this time will eliminate future service problems.

It is recommended that vertical suction risers not be up-sized. Proper oil return to the compressor should be maintained with suction gas velocity.

Filter Drier

The filter drier is very important for proper system operation and reliability. If the drier is shipped loose, it must be installed by the installer in the field. Unit warranty will be void, if the drier is not installed.

Installation of Line Sets

DO NOT fasten liquid or suction lines in direct contact with the floor or ceiling joist. Use an insulated or suspension type of hanger. Keep both lines separate, and always insulate the suction line. Liquid line runs (30 feet or more) in an attic will require insulation. Route refrigeration line sets to minimize length.

DO NOT let refrigerant lines come in direct contact with foundation. When running refrigerant lines through the foundation or wall, openings should allow for a sound and vibration absorbing material to be placed or installed between tubing and foundation. Any gap between foundation or wall and refrigerant lines should be filled with a vibration damping material.

⚠ CAUTION

If ANY refrigerant tubing is required to be buried by state or local codes, provide a 6 inch vertical rise at service valve.

LINE SET

IMPORTANT — Refrigerant lines must not contact structure.

INSTALLATION

Line Set Isolation — The following illustrations are examples of proper refrigerant line set isolation:

REFRIGERANT LINE SET — TRANSITION FROM VERTICAL TO HORIZONTAL

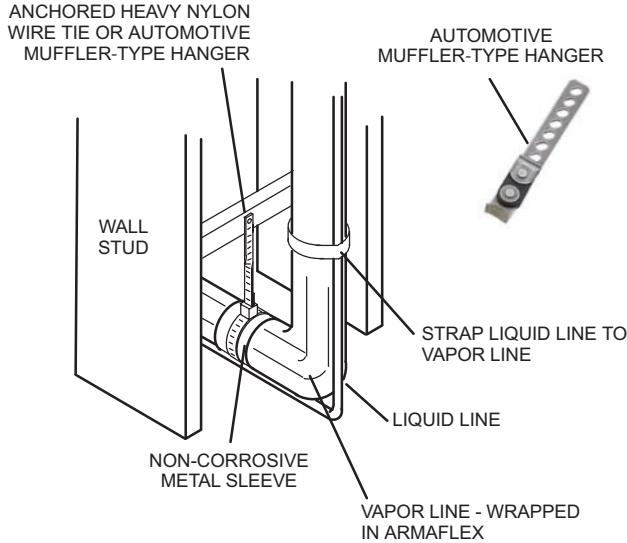

REFRIGERANT LINE SET — INSTALLING HORIZONTAL RUNS

To hang line set from joist or rafter, use either metal strapping material or anchored heavy nylon wire ties.

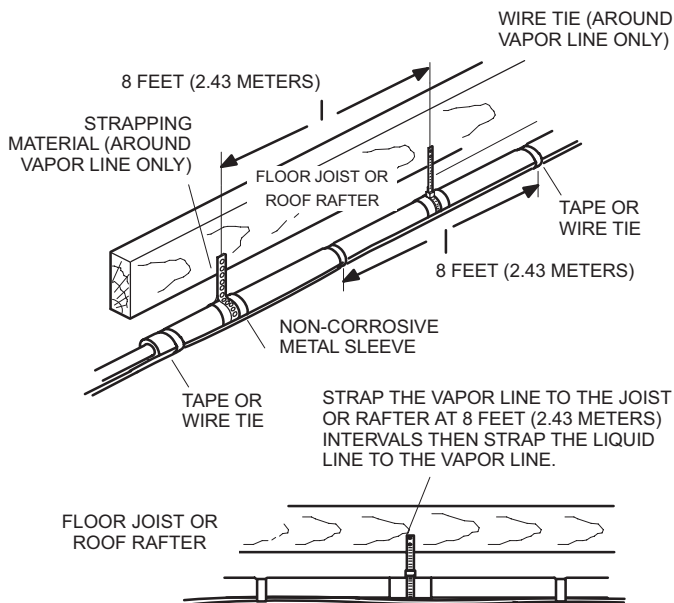

REFRIGERANT LINE SET — INSTALLING VERTICAL RUNS (NEW CONSTRUCTION SHOWN)

NOTE — Insulate liquid line when it is routed through areas where the surrounding ambient temperature could become higher than the temperature of the liquid line or when pressure drop is equal to or greater than 20 psig.

IMPORTANT — Refrigerant lines must not contact wall

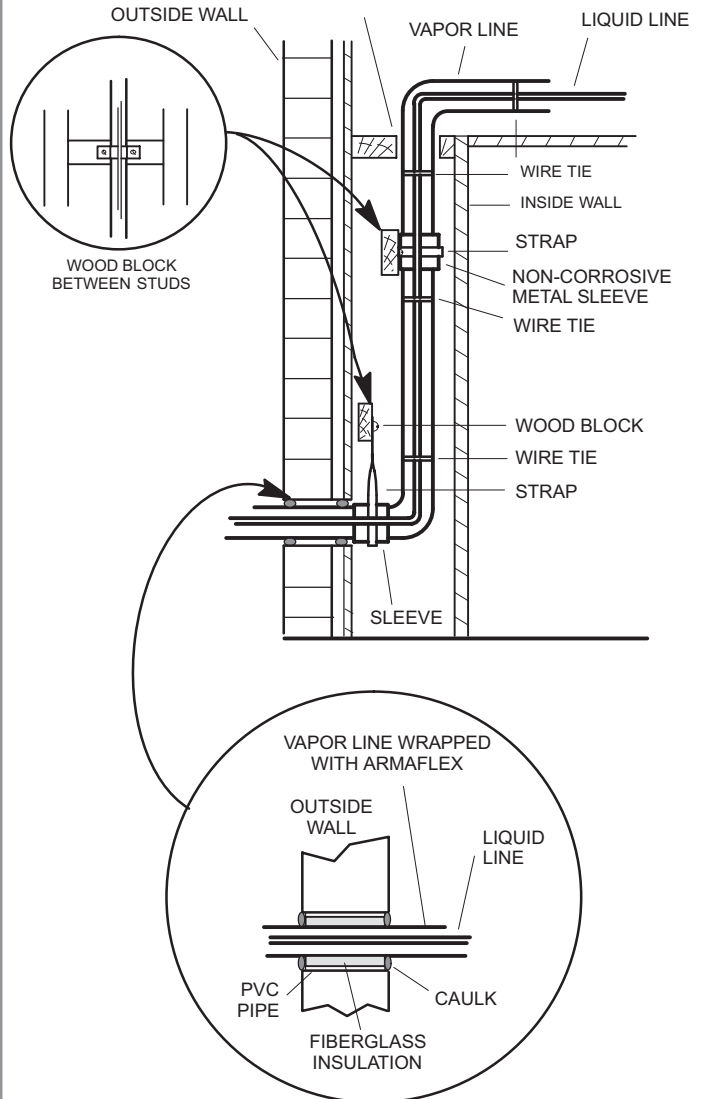

NOTE — Similar installation practices should be used if line set is to be installed on exterior of outside wall.

WARNING — Polyol ester (POE) oils used with HFC-410A refrigerant absorb moisture very quickly. It is very important that the refrigerant system be kept closed as much as possible. DO NOT remove line set caps or service valve stub caps until you are ready to make connections.

Figure 5. Line Set Installation

Flushing Line Sets

If the unit will be installed in an existing system that uses an indoor unit or line sets charged with R-22 refrigerant, installer must perform the following flushing procedure.

NOTE: Existing system components (including line set and indoor coil) must be an AHRI match with the unit in order to fulfill unit warranty requirements.

⚠ WARNING

Refrigerant must be reclaimed in accordance with national and local codes.

⚠ CAUTION

Do **NOT** attempt to flush and re-use existing line sets or indoor coil when the system contains contaminants (i.e., compressor burn out).

NOTE

“Clean refrigerant” is any refrigerant in a system that has not had compressor burnout. If the system has experienced burnout, it is recommended that the existing line set and indoor coil be replaced.

NOTE

In lieu of R-410A, an industry-standard flushing agent may also be used.

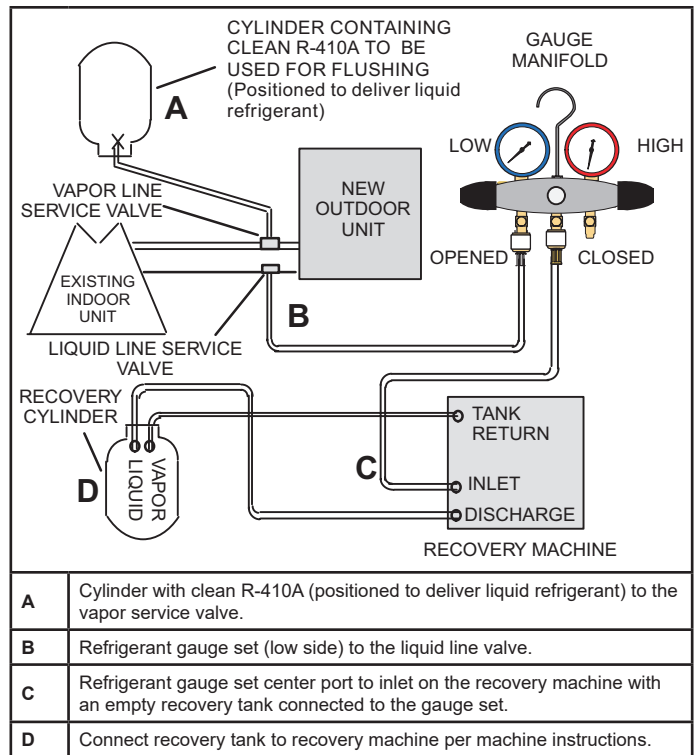

Figure 6.

1. Connect gauges and equipment as shown in Figure 6.
2. Set the recovery machine for liquid recovery and start the recovery machine. Open the gauge set valves to allow the recovery machine to pull a vacuum on the existing system line set and indoor unit coil.
3. Position the cylinder of clean R-410A for delivery of liquid refrigerant and open its valve to allow liquid refrigerant to flow into the system through the vapor line valve. Allow the refrigerant to pass from the cylinder and through the line set and the indoor unit coil before it enters the recovery machine.
4. After all of the liquid refrigerant has been recovered, switch the recovery machine to vapor recovery so that all of the R-410A vapor is recovered. Allow the recovery machine to pull the system down to 0.
5. Close the valve on the inverted R-410A drum and the gauge set valves. Pump the remaining refrigerant out of the recovery machine and turn the machine off.

Refrigerant Piping - Install Indoor Expansion Valve

This outdoor unit is designed for use in systems that include an expansion valve metering device (purchased separately) at the indoor coil. See the Product Specifications for approved expansion valve kit match-ups and application information. The check expansion valve unit can be installed internal or external to the indoor coil. In applications where an uncased coil is being installed in a field-provided plenum, install the check/expansion valve in a manner that will provide access for future field service of the expansion valve. Refer to below illustration for reference during installation of expansion valve unit.

INDOOR EXPANSION VALVE INSTALLATION

TWO PIECE
PATCH PLATE
(UNCASED
COIL ONLY)

(Uncased Coil Shown)

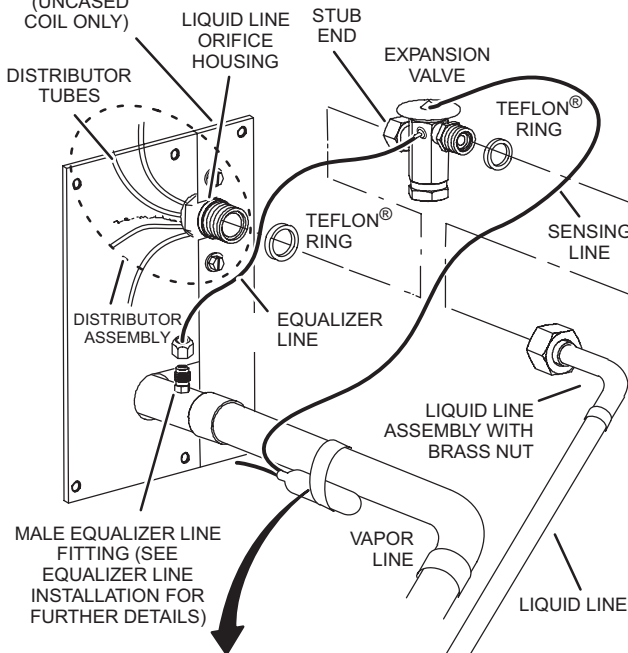

Sensing bulb insulation is required if mounted external to the coil casing. sensing bulb installation for bulb positioning.

- 3 - Install one of the provided Teflon® rings around the stubbed end of the check expansion valve and lightly lubricate the connector threads and expose surface of the Teflon® ring with refrigerant oil.
- 4 - Attach the stubbed end of the check expansion valve to the liquid line orifice housing. Finger tighten and use an appropriately sized wrench to turn an additional 1/2 turn clockwise as illustrated in the figure above, or tighten to 20 ft-lb.
- 5 - Place the remaining Teflon® washer around the other end of the check expansion valve. Lightly lubricate connector threads and expose surface of the Teflon® ring with refrigerant oil.
- 6 - Attach the liquid line assembly to the check expansion valve. Finger tighten and use an appropriately sized wrench to turn an additional 1/2 turn clockwise as illustrated in the figure above or tighten to 20 ft-lb.

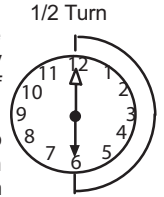

SENSING BULB INSTALLATION

- 1 - Attach the vapor line sensing bulb in the proper orientation as illustrated to the right using the clamp and screws provided.

NOTE - Though it is preferred to have the sensing bulb installed on a horizontal run of the vapor line, installation on a vertical run of piping is acceptable if necessary.

NOTE - Confirm proper thermal contact between vapor line and check/expansion bulb before insulating the sensing bulb once installed.

- 2 - Connect the equalizer line from the check expansion valve to the equalizer vapor port on the vapor line. Finger tighten the flare nut plus 1/8 turn (7 ft-lbs) as illustrated below.

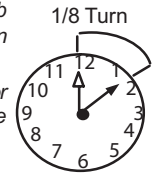

EQUALIZER LINE INSTALLATION

- 1 - Remove and discard either the flare seal cap or flare nut with copper flare seal bonnet from the equalizer line port on the vapor line as illustrated in the figure below.
- 2 - Remove the field-provided fitting that temporarily reconnected the liquid line to the indoor unit's distributor assembly.

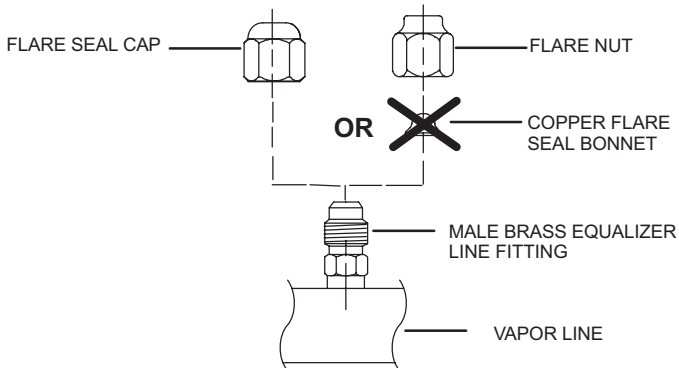

ON LINES SMALLER THAN 7/8", MOUNT SENSING BULB AT EITHER THE 3 OR 9 O'CLOCK POSITION.

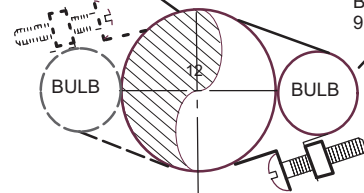

ON 7/8" AND LARGER LINES, MOUNT SENSING BULB AT EITHER THE 4 OR 8 O'CLOCK POSITION.

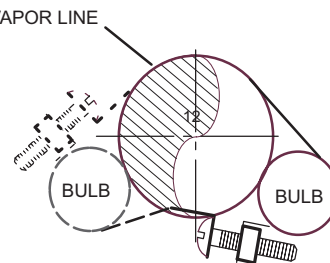

NOTE - NEVER MOUNT THE SENSING BULB ON BOTTOM OF LINE.

Refrigerant Piping - Brazing Procedures

1 CUT AND DEBUR

Cut ends of the refrigerant lines square (free from nicks or dents) and debur the ends. The pipe must remain round. Do not crimp end of the line.

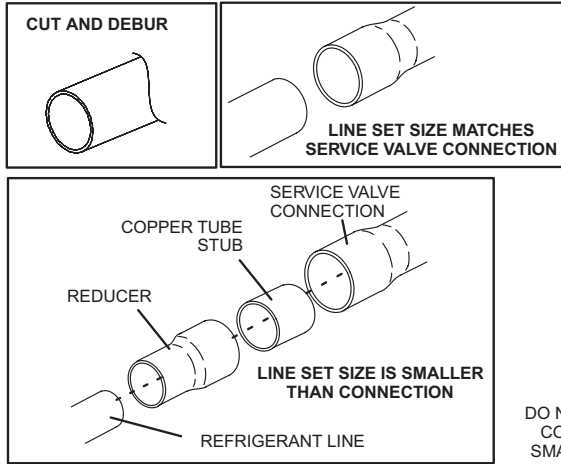

2 CAP AND CORE REMOVAL

Remove service cap and core from both the vapor and liquid line service ports.

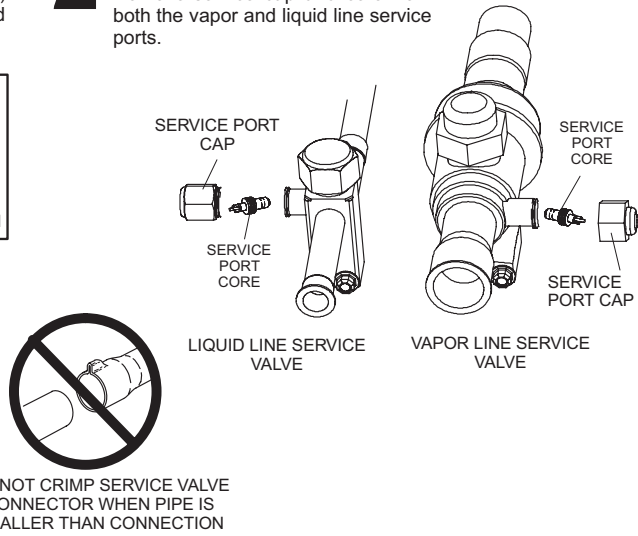

3 ATTACH THE MANIFOLD GAUGE SET FOR BRAZING LIQUID AND VAPOR LINE SERVICE VALVES

Flow regulated nitrogen (at 1 to 2 psig) through the low-side refrigeration gauge set into the liquid line service port valve, and out of the vapor line service port valve.

- A - Connect gauge set low pressure side to liquid line service valve (service port).
- B - Connect gauge set center port to bottle of nitrogen with regulator.
- C - Remove core from valve in vapor line service port to allow nitrogen to escape.

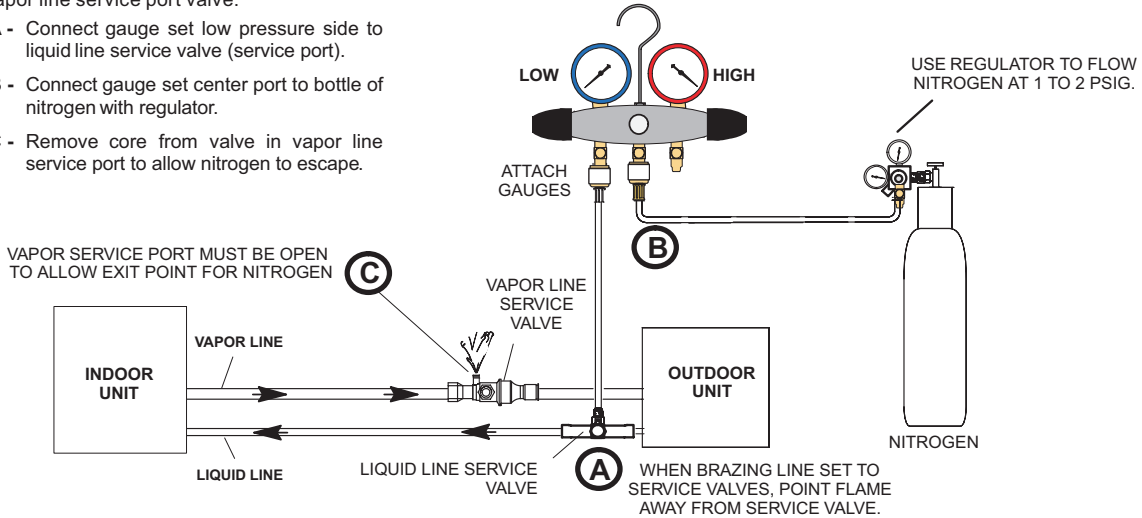

NOTE

Use a manifold gauge set designed for use on R-410A refrigerant systems.

⚠ WARNING

Before brazing, ensure the system is fully recovered of all refrigerant. Application of a brazing torch to a pressurized system may result in ignition of the refrigerant and oil mixture. Check the high and low pressures before applying heat.

⚠ WARNING

Brazing alloys and flux contain materials which are hazardous to your health.

Avoid breathing vapors or fumes from brazing operations. Perform operations only in well-ventilated areas.

Wear gloves and protective goggles or face shield to protect against burns.

Wash hands with soap and water after handling brazing alloys and flux.

4 WRAP SERVICE VALVES

To help protect service valve seals during brazing, wrap water-saturated cloths around service valve bodies and copper tube stubs. Use additional water-saturated cloths underneath the valve body to protect the base paint.

5 FLOW NITROGEN

Flow regulated nitrogen (at 1 to 2 psig) through the refrigeration gauge set into the valve stem port connection on the liquid service valve and out of the vapor valve stem port. See steps 3A, 3B and 3C on manifold gauge set connections.

6 BRAZE LINE SET

Wrap both service valves with water-saturated cloths as illustrated here and as mentioned in step 4, before brazing to line set. Cloths must remain water-saturated throughout the brazing and cool-down process.

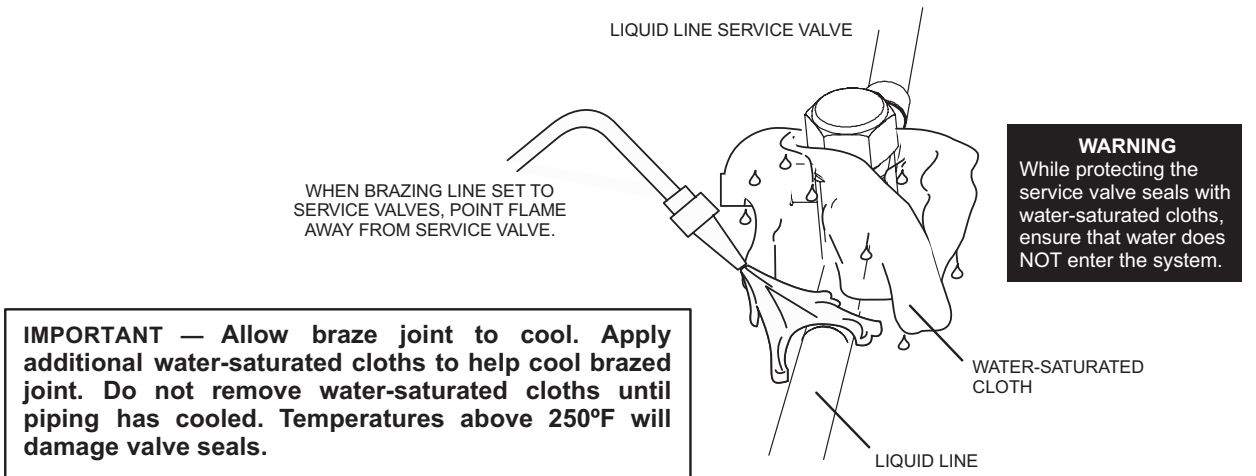

WARNING

FIRE, PERSONAL INJURY, OR PROPERTY DAMAGE may result if you do not wrap a water-saturated cloth around both liquid and suction line service valve bodies and copper tube stub while brazing the line set! The braze, when complete, must be quenched with water to absorb any residual heat.

Do not open service valves until refrigerant lines and indoor coil have been leak-tested and evacuated. Refer to Leak Test and Evacuation section of this manual.

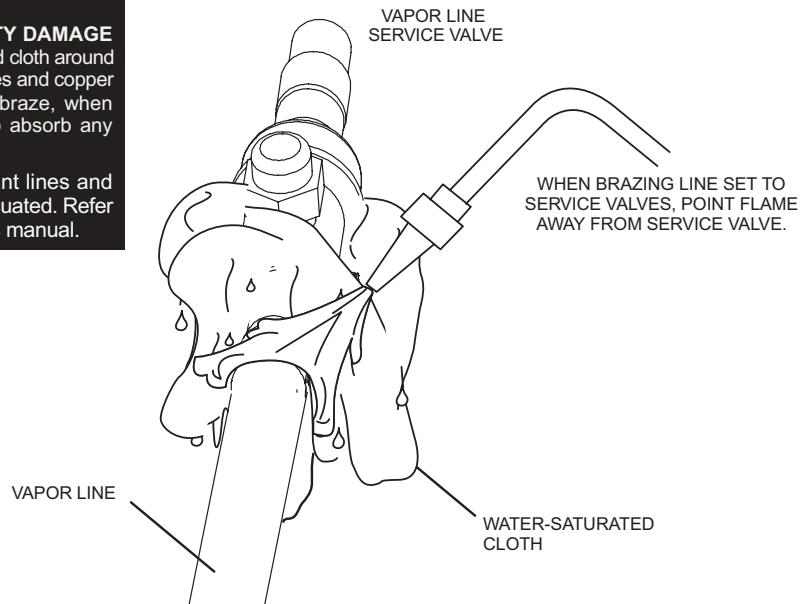

7 PREPARATION FOR NEXT STEP

After all connections have been brazed, disconnect manifold gauge set from service ports. Apply additional water-saturated cloths to both services valves to cool piping. Once piping is cool, remove all water-saturated cloths.

Leak Test and Evacuation

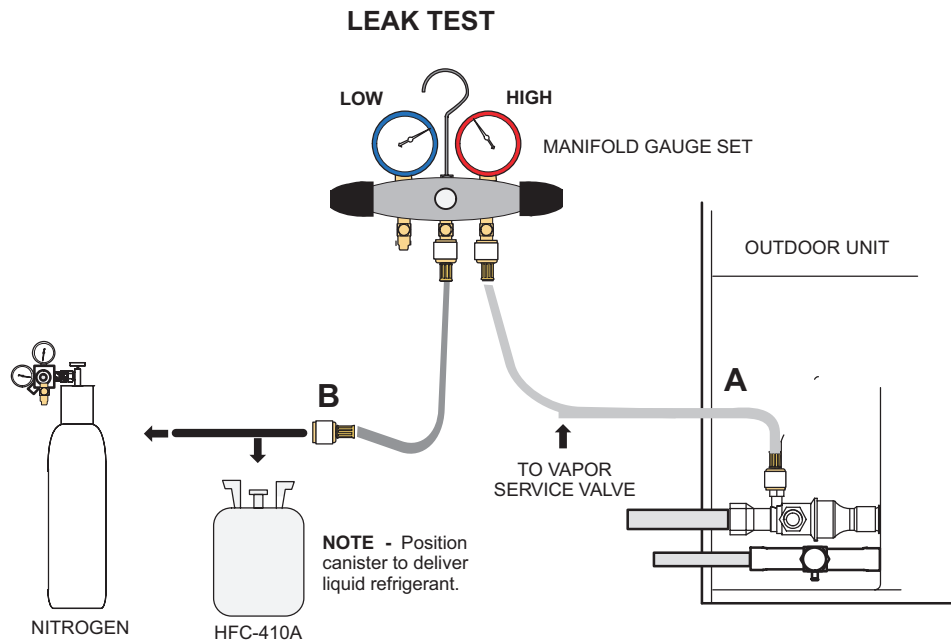

1 CONNECT GAUGE SET

- A** - Connect the high pressure hose of an HFC-410A manifold gauge set to the vapor valve service port.
NOTE - Normally, the high pressure hose is connected to the liquid line port. However, connecting it to the vapor port better protects the manifold gauge set from high pressure damage.
- B** - With both manifold valves closed, connect the cylinder of HFC-410A refrigerant to the center port of the manifold gauge set.
NOTE - Later in the procedure, the HFC-410A container will be replaced by the nitrogen container.

2 TEST FOR LEAKS

After the line set has been connected to the indoor and outdoor units, check the line set connections and indoor unit for leaks. Use the following procedure to test for leaks:

- A** - With both manifold valves closed, connect the cylinder of HFC-410A refrigerant to the center port of the manifold gauge set. Open the valve on the HFC-410A cylinder (vapor only).
- B** - Open the high pressure side of the manifold to allow HFC-410A into the line set and indoor unit. Weigh in a trace amount of HFC-410A. [A trace amount is a maximum of two ounces (57 g) refrigerant or three pounds (31 kPa) pressure.] Close the valve on the HFC-410A cylinder and the valve on the high pressure side of the manifold gauge set. Disconnect the HFC-410A cylinder.
- C** - Connect a cylinder of nitrogen with a pressure regulating valve to the center port of the manifold gauge set.
- D** - Adjust nitrogen pressure to 150 psig (1034 kPa). Open the valve on the high side of the manifold gauge set in order to pressurize the line set and the indoor unit.
- E** - After a few minutes, open one of the service valve ports and verify that the refrigerant added to the system earlier is measurable with a leak detector.
- F** - After leak testing, disconnect gauges from service ports.
NOTE - Service valve cores remain removed for the following evacuation procedure.

3 CONNECT GAUGE SET

NOTE - Remove cores from service valves (if not already done).

- A - Connect low side of manifold gauge set with 1/4 SAE in-line tee to vapor line service valve
- B - Connect high side of manifold gauge set to liquid line service valve
- C - Connect available micron gauge connector on the 1/4 SAE in-line tee.
- D - Connect the vacuum pump (with vacuum gauge) to the center port of the manifold gauge set. The center port line will be used later for both the HFC-410A and nitrogen containers.

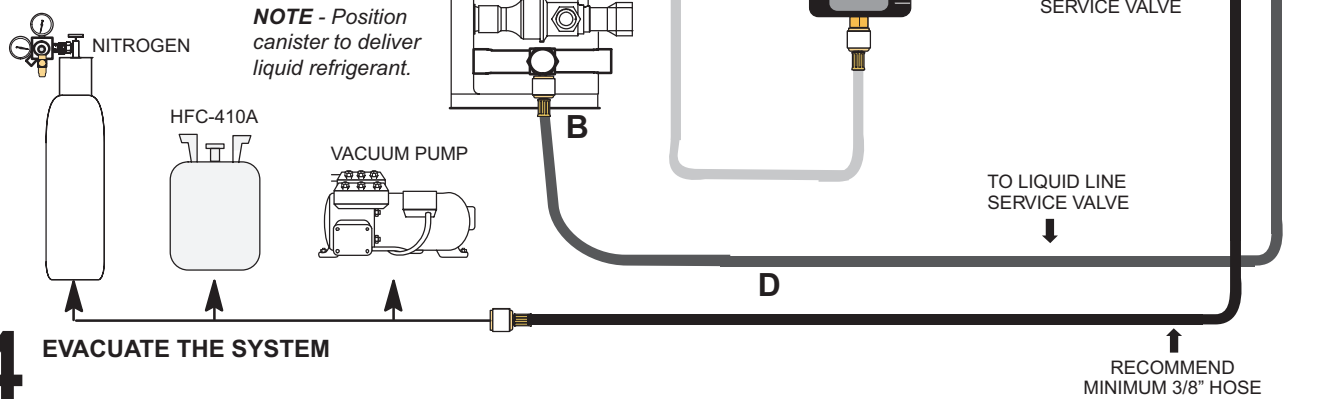

4 EVACUATE THE SYSTEM

- A - Open both manifold valves and start the vacuum pump.
- B - Evacuate the line set and indoor unit until a slight vacuum is indicated on the micron gauge (approximately 23,000 microns or 29.01 inches of mercury).
 - NOTE** - During the early stages of evacuation, it is desirable to close the manifold gauge valve at least once. A rapid rise in pressure indicates a relatively large leak. If this occurs, **repeat the leak testing procedure**.
 - NOTE** - The term **absolute pressure** means the total actual pressure above absolute zero within a given volume or system. Absolute pressure in a vacuum is equal to atmospheric pressure minus vacuum pressure.
- C - When the absolute pressure reaches 23,000 microns (29.01 inches of mercury), perform the following:
 - Close manifold gauge valves.
 - Close valve on vacuum pump.
 - Turn off vacuum pump.
 - Disconnect manifold gauge center port hose from vacuum pump.
 - Attach manifold center port hose to a nitrogen cylinder with pressure regulator set to 150 psig (1034 kPa) and purge the hose.
 - Open manifold gauge valves to break the vacuum in the line set and indoor unit.
 - Close manifold gauge valves.
- D - Shut off the nitrogen cylinder and remove the manifold gauge hose from the cylinder. Open the manifold gauge valves to release the nitrogen from the line set and indoor unit.
- E - Reconnect the manifold gauge to the vacuum pump, turn the pump on, and continue to evacuate the line set and indoor unit until the absolute pressure does not rise above 500 microns (29.9 inches of mercury) within a 20-minute period after shutting off the vacuum pump and closing the manifold gauge valves.
- F - When the absolute pressure requirement above has been met, disconnect the manifold hose from the vacuum pump and connect it to a cylinder of HFC-410A positioned to deliver liquid refrigerant. Open the manifold gauge valve 1 to 2 psig in order to release the vacuum in the line set and indoor unit.
- G - Perform the following:
 - Close manifold gauge valves.
 - Shut off HFC-410A cylinder.
 - Reinstall service valve cores by removing manifold hose from service valve. Quickly install cores with core tool while maintaining a positive system pressure.
 - Replace stem caps and finger tighten them, then tighten an additional one-sixth (1/6) of a turn as illustrated.
- H - Open suction service valve first before liquid valve to release the unit charge into the system. Replace valve caps and tighten (8 ft. lb.). Caps are the primary seal.

WARNING !

Possible equipment damage.

Avoid deep vacuum operation. Do not use compressors to evacuate a system. Extremely low vacuum can cause internal arcing and compressor failure. Damage caused by deep vacuum operation will void warranty.

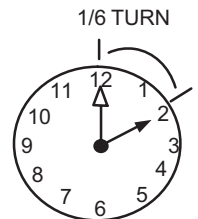

Electrical Wiring

All field wiring must be done in accordance with the National Electrical Code (NEC) recommendations, Canadian Electrical Code (CEC) and CSA Standards, or local codes, where applicable.

⚠ WARNING

Electrical Shock Hazard!



Turn OFF electric power before connecting unit, performing any maintenance or removing panels or doors. More than one disconnect may be required to turn off all power.

FAILURE TO DO SO COULD RESULT IN BODILY INJURY OR DEATH.

⚠ WARNING

Unit must be grounded in accordance with national and local codes. Failure to ground unit properly can result in personal injury or death.

⚠ WARNING

Line voltage is present at all components when unit is not in operation on units with single pole contactors. Disconnect all remote electric power supplies before opening access panel. Unit may have multiple power supplies. Failure to disconnect all power supplies could result in personal injury or death.

Refer to the furnace or blower coil Installation Instructions for additional wiring application diagrams and refer to unit rating plate for minimum circuit ampacity and maximum overcurrent protection size.

1. Install line voltage power supply to unit from a properly sized disconnect switch. Any excess high voltage field wiring should be trimmed or secured away from the low voltage field wiring.
2. Ground unit at unit disconnect switch or to an earth ground. To facilitate conduit, a hole is in the bottom of the control box. Connect conduit to the control box using a proper conduit fitting. Units are approved for use only with copper conductors. 24V Class II circuit connections are made in the low voltage junction box. A complete unit wiring diagram is located inside the unit control box cover.

3. Install room thermostat according to thermostat installation instruction and on an inside wall that is not subject to drafts, direct sunshine, or other heat sources.
4. Install low voltage wiring from outdoor to indoor unit and from thermostat to indoor unit (see Figure 7).
5. Do not bundle any excess 24V control wire inside control box. Run control wire through installed wire tie and tighten wire tie to provide low voltage strain relief and to maintain separation of field-installed low and high voltage circuits.

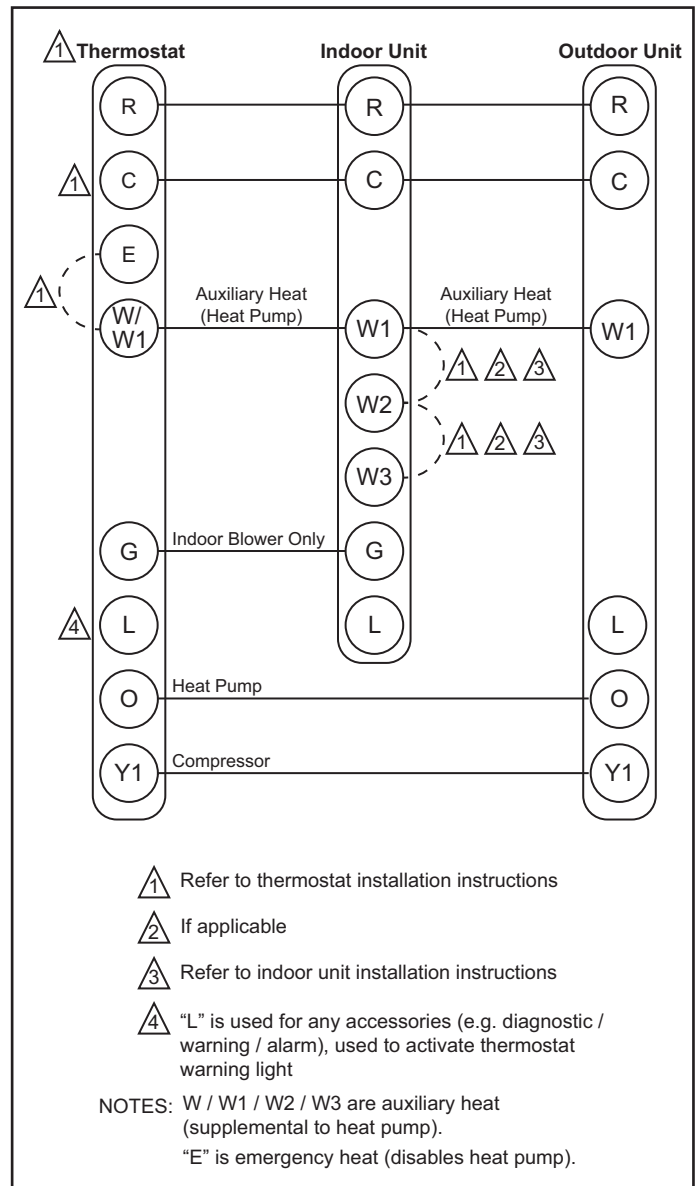

Figure 7. Thermostat Designations - Non-Communicating

Operation

The outdoor unit and indoor blower cycle on demand from the room thermostat. When the thermostat blower switch is in the ON position, the indoor blower operates continuously.

Emergency Heat Function (Room Thermostat)

An emergency heat function is designed into some room thermostats. This feature is applicable when isolation of outdoor unit is required or when auxiliary electric heat is staged by outdoor thermostats.

For heat pumps equipped with outdoor thermostats, to bypass electric heat, a field relay is required to properly activate the emergency heat function of the room thermostat.

Pressure Switch Connections

The unit's automatic reset pressure switches (LO PS - S87 and HI PS - S4) are factory-wired into the control board on the LO-PS and HI-PS terminals, respectively.

Low Pressure Switch (LO-PS)

When the low pressure switch trips, the defrost board will cycle off the compressor, and the strike counter in the board will count one strike. The low pressure switch is ignored under the following conditions:

- during the defrost cycle and 90 seconds after the termination of defrost

- when the average ambient sensor temperature is below 15° F (-9°C)
- for 90 seconds following the start up of the compressor
- during "test" mode

High Pressure Switch (HI-PS)

When the high pressure switch trips, the defrost board will cycle off the compressor, and the strike counter in the board will count one strike.

Pressure Switch Settings

- High Pressure (auto reset) - trip at 590 psig; reset at 418.
- Low Pressure (auto reset) - trip at 25 psig; reset at 40.

5-Strike Lockout Feature

The internal control logic of the board counts the pressure switch trips only while the Y1 (Input) line is active. If a pressure switch opens and closes four times during a Y1 (Input), the control logic will reset the pressure switch trip counter to zero at the end of the Y1 (Input). If the pressure switch opens for a fifth time during the current Y1 (Input), the control will enter a lockout condition.

The 5-strike pressure switch lockout condition can be reset by cycling OFF the 24-volt power to the control board or by shorting the TEST pins between 1 and 2 seconds. All timer functions (run times) will also be reset.

If a pressure switch opens while Y1 is engaged, a 5-minute short cycle will occur after the switch closes.

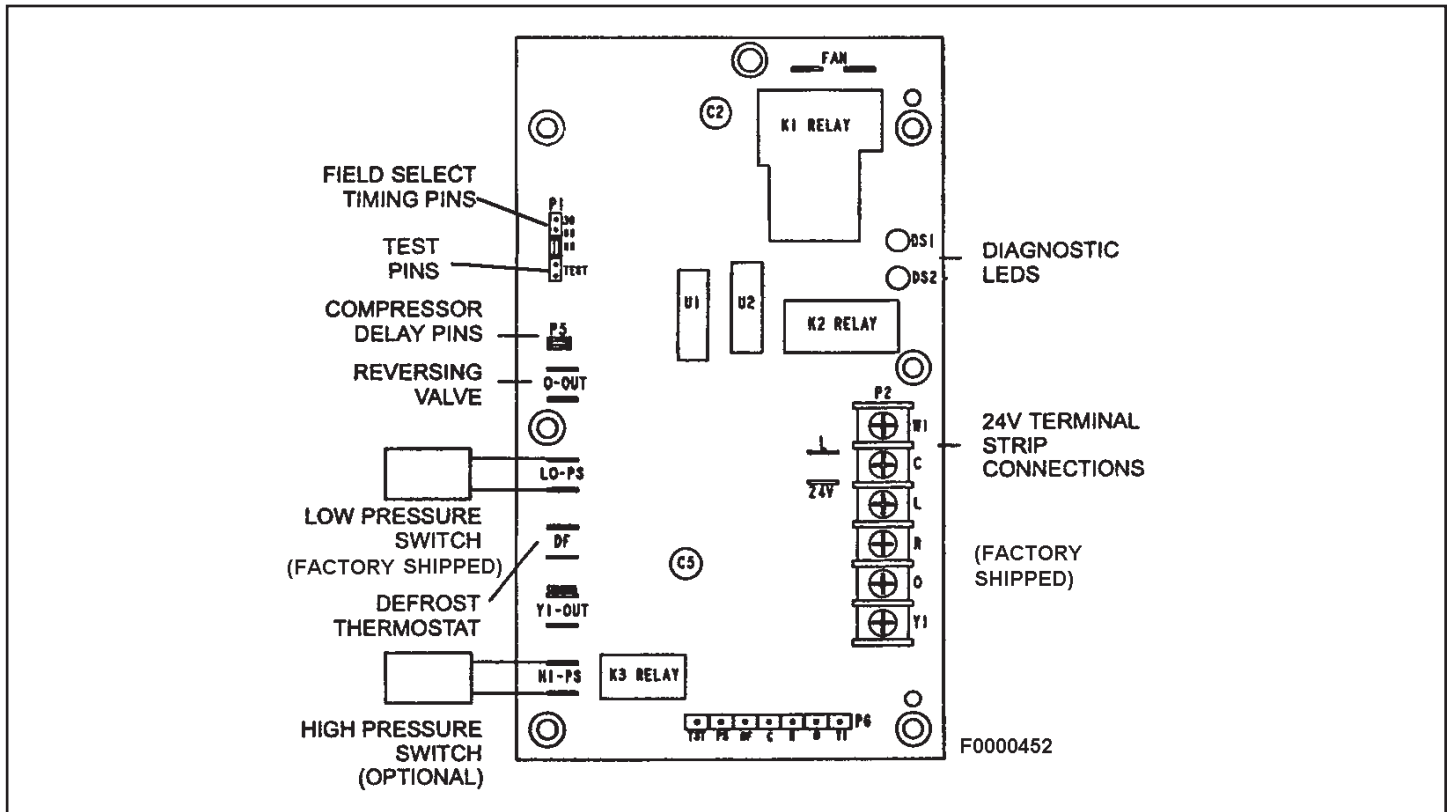

Figure 8. Outdoor Unit Control Board

Defrost System

The defrost system includes two (2) components: a defrost thermostat and a control board.

Defrost Thermostat

The defrost thermostat is located on the outdoor coil of most models and on the liquid line between the check/expansion valve and the distributor on R-410A TXV equipped models. When defrost thermostat senses 29°F (42°F on R-410A TXV's) or cooler, the thermostat contacts close and send a signal to the control board to start the defrost timing. It also terminates defrost when the liquid line warms up to 60°F.

Control Board

The control board includes the combined functions of a time/temperature defrost control, defrost relay, diagnostic LEDs and terminal strip for field wiring connections.

The control provides automatic switching from normal heating operation to defrost mode and back. During compressor cycle, the control accumulates compressor run times at 30-, 60-, or 90-minute field-adjustable intervals. If the defrost thermostat is closed when the selected compressor run time interval ends (call for defrost), the defrost relay is energized and defrost begins. The factory setting is 90 minutes which is the optimum efficiency setting.

Defrost Timing Pins

Each timing pin selection provides a different accumulated compressor run time period for one defrost cycle. This time period must occur before a defrost cycle is initiated. The defrost interval can be adjusted to 30 (T1), 60 (T2), or 90 (T3) minutes. If the timing selector jumper is not in place the control defaults to a 90-minute defrost interval. The maximum defrost period is 14 minutes and cannot be adjusted.

A TEST option is provided for troubleshooting. The TEST mode may be started any time the unit is in the heating mode and the defrost thermostat is closed or jumpered. If the jumper is in the TEST position at power-up, the control will ignore the test pins. When the jumper is placed across the TEST pins for 2 seconds, the control will enter the defrost mode. If the jumper is removed before an additional 5 second period has elapsed (7 seconds total), the unit will remain in defrost mode until the defrost thermostat opens or 14 minutes have passed. If the jumper is not removed until after the additional 5 second period has elapsed, the defrost will terminate and the test option will not function again until the jumper is removed and re-applied.

Time Delay

The timed-off delay is 5 minutes long. The delay helps to protect the compressor from short-cycling in case the power to the unit is interrupted or a pressure switch opens. The delay is bypassed by placing the timer select jumper across the TEST pins for 0.5 seconds.

Compressor Delay

The defrost board has a field-selectable function to reduce occasional sounds that may occur while the unit is cycling in and out of the defrost mode. When a jumper is installed on the DELAY pins, the compressor will be cycled off for 30 seconds going in and out of the defrost mode. Units are shipped with jumper installed on DELAY pins.

NOTE: *The 30 second compressor delay feature (known as the quiet shift) **must** be deactivated during any unit performance testing. The feature is deactivated by removing the jumper located on the compressor delay pins on the control board mounted inside the unit control box. This feature is optional for the homeowner, but may impact testing performance.*

Diagnostic LEDs

The state (Off, On, Flashing) of two LEDs on the defrost board (DS1 [Red] and DS2 [Green]) indicate diagnostics conditions that are described in Table 4.

Mode	Green LED (DS2)	Red LED (DS1)
No power to control	Off	Off
Normal operation / power to control	Simultaneous slow flash	
Anti-short cycle lockout	Alternating slow flash	
Low pressure switch fault	Off	Slow flash
Low pressure switch lockout	Off	On
High pressure switch fault	Slow flash	Off
High pressure switch lockout	On	Off

Table 4.

Maintenance

Regular Maintenance Requirements

Your system should be regularly inspected by a qualified service technician. These regular visits may include (among other things) checks for:

- Motor operation
- Ductwork air leaks
- Coil & drain pan cleanliness (indoor & outdoor)
- Electrical component operation & wiring check
- Proper refrigerant level & refrigerant leaks
- Proper airflow
- Drainage of condensate
- Air filter(s) performance
- Blower wheel alignment, balance & cleaning
- Primary & secondary drain line cleanliness
- Proper defrost operation (heat pumps)

Air Filter

Inspect air filters at least monthly and replace or clean as required. Disposable filters should be replaced. Washable filters may be cleaned by soaking in mild detergent and rinsing with cold water. Allow filter to dry before reinstalling. Replace filters with the arrows pointing in the direction of airflow. Dirty filters are the most common cause of poor heating / cooling performance and compressor failures.

Indoor Coil

If the system has been operated with a clean filter in place, it should require minimal cleaning. If cleaning is needed, call your dealer for service.

Condensate Drain

During cooling season check at least monthly for free flow of drainage and clean if necessary.

Condenser Coils

Grass cuttings, leaves, dirt, dust, lint from clothes dryers, and foliage from trees can be drawn into coils by movement of the air. Clogged condenser coils will lower the efficiency of your unit and could cause damage to the condenser.

Periodically, debris should be brushed from the condenser coils. Use a soft bristle brush with light pressure only. DO NOT damage or bend condenser coil fins. Damaged or bent fins may affect unit operation.

WARNING

SHARP OBJECT HAZARD!

Condenser coils have sharp edges. Wear adequate body protection on body extremities (e.g. gloves).

FAILURE TO FOLLOW THIS WARNING COULD RESULT IN BODILY INJURY.

Painted Surfaces

For maximum protection of the unit's finish, a good grade of automobile wax should be applied every year. In geographical areas where water has a high concentration of minerals (calcium, iron, sulfur, etc.), it is recommended that lawn sprinklers not be allowed to spray the unit. In such applications, the sprinklers should be directed away from the unit. Failure to follow this precaution may result in premature deterioration of the unit finish and metal components.

In sea coast areas, special maintenance is required due to the corrosive atmosphere provided by the high salt concentration in ocean mists and the air. Periodic washing of all exposed surfaces and coil will add additional life to your unit. Please consult your installing dealer for proper procedures in your geographic area.

Homeowner Information

WARNING

ELECTRICAL SHOCK HAZARD!

Turn OFF electric power to unit before performing any maintenance or removing panels or doors.

FAILURE TO DO SO COULD RESULT IN BODILY INJURY OR DEATH.

Heat Pump Operation

Your new heat pump has several characteristics that you should be aware of:

- Heat pumps satisfy heating demand by delivering large amounts of warm air into the living space. This is quite different from gas-or oil-fired furnaces or an electric furnace which deliver lower volumes of considerably hotter air to heat the space.
- Do not be alarmed if you notice frost on the outdoor coil in the winter months. Frost develops on the outdoor coil during the heating cycle when temperatures are below 45°F. An electronic control activates a defrost cycle lasting 5 to 15 minutes at preset intervals to clear the outdoor coil of the frost.

- During the defrost cycle, you may notice steam rising from the outdoor unit. This is a normal occurrence. The thermostat may engage auxiliary heat during the defrost cycle to satisfy a heating demand; however, the unit will run to normal operation at the conclusion of the defrost cycle.

In case of extended power outage...

If the outdoor temperature is below 50°F and power to your outdoor unit has been interrupted for one hour or longer, observe the following when restoring power to your heat pump system.

- Set the room thermostat selector to the “Emergency Heat” setting to obtain temporary heat for a minimum of 6 hours. This will allow system refrigerant pressures and temperatures enough time to return to a stabilized condition.
- In Emergency Heat mode, all heating demand is satisfied by auxiliary heat; heat pump operation is locked out. After a 6 hour “warm-up” period, the thermostat can then be switched to the “Heat” setting and normal heat pump operation may resume.

Thermostat Operation

The wall-mounted thermostat controls your heat pump. The thermostat is available in various configurations from different manufacturers. The information below is typical for most thermostats. Ask your dealer for specific information regarding the model of thermostat installed.

Fan Switch

In AUTO or INT (intermittent) mode, the blower operates only when the thermostat calls for heating or cooling. This mode is generally preferred when humidity control is a priority.

The ON or CONT mode provides continuous indoor blower operation, regardless of whether the compressor or auxiliary heat are operating. This mode is required when constant air circulation or filtering is desired.

On models without a fan selection switch, the fan will cycle with the outdoor unit.

System Switch

Set the system switch for heating, cooling or auto operation. The auto mode allows the heat pump to automatically switch from heating mode to cooling mode to maintain predetermined comfort settings. Many heat pump thermostats are also equipped with an emergency heat mode which locks out heat pump operation and provides temporary heat supplied by the auxiliary heat.

Indicating Light

Most heat pump thermostats have an amber light which indicates when the heat pump is operating in the emergency heat mode.

Temperature Indicator

The temperature indicator displays the actual room temperature.

Important System Information

- Your system should never be operated without a clean air filter properly installed.
- Return air and supply air registers should be free from restrictions or obstructions to allow full flow of air.

IF YOUR SYSTEM DOES NOT WORK, BEFORE REQUESTING A SERVICE CALL:

1. Ensure thermostat is set below (cooling) or above (heating) room temperature and that the system lever is in the “COOL”, “HEAT” or “AUTO” position.
2. Inspect your return air filter: If it is dirty, your heat pump may not function properly.
3. Check indoor and outdoor disconnect switches. Confirm circuit breakers are ON or that fuses have not blown. Reset breakers/replace fuses as necessary.
4. Inspect the outdoor unit for clogged condenser coils, (grass cuttings, leaves, dirt, dust or lint). Ensure that branches, twigs or other debris are not obstructing the condenser fan.

IF YOUR SYSTEM STILL DOES NOT OPERATE, CONTACT YOUR SERVICING DEALER.

Be sure to describe the problem, and have the model and serial numbers of the equipment available.

If warranty replacement parts are required, the warranty must be processed through a qualified distribution location.

⚠ WARNING

To prevent personal injury, or damage to panels, unit or structure, be sure to observe the following:

While installing or servicing this unit, carefully stow all removed panels out of the way, so that the panels will not cause injury to personnel, nor cause damage to objects or structures nearby, nor will the panels be subjected to damage (e.g., being bent or scratched).

While handling or stowing the panels, consider any weather conditions, especially windy conditions, that may cause panels to be blown around and battered.

REMOVAL

STEP 1

TO REMOVE PANEL, REMOVE MOUNTING SCREWS SECURING PANEL TO THE UNIT.

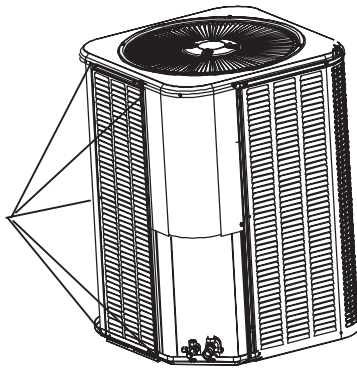

STEP 2

SLIGHTLY LIFT PANEL IN ORDER TO CLEAR SIDE LIPS OF PANEL FROM BASE OF UNIT.

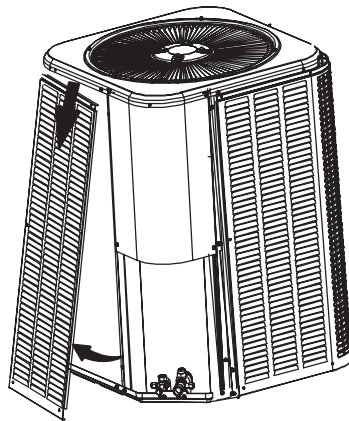

STEP 3

TILT PANEL OUT SLIGHTLY AND PULL DOWNWARD TO REMOVE.

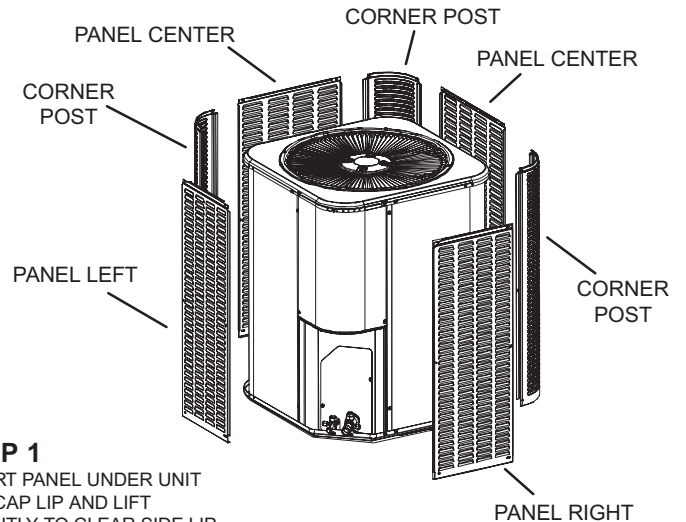

STEP 1

INSERT PANEL UNDER UNIT TOP CAP LIP AND LIFT SLIGHTLY TO CLEAR SIDE LIP OF PANEL FROM BASE.

STEP 2

MOVE PANEL IN TOWARDS UNIT. ALIGN LEFT/RIGHT SIDE LIPS OF PANEL WITH GROOVE INSERTS ALONG LEFT/RIGHT SIDE OF UNIT.

STEP 3

SECURE PANEL, WITH MOUNTING SCREWS.

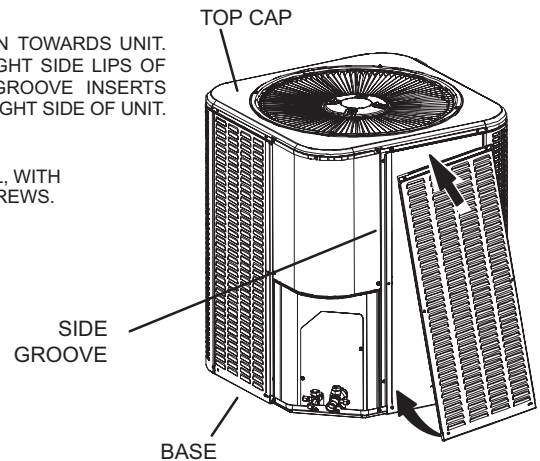

PANEL INSTALLATION

Figure 9. Removing Louvers

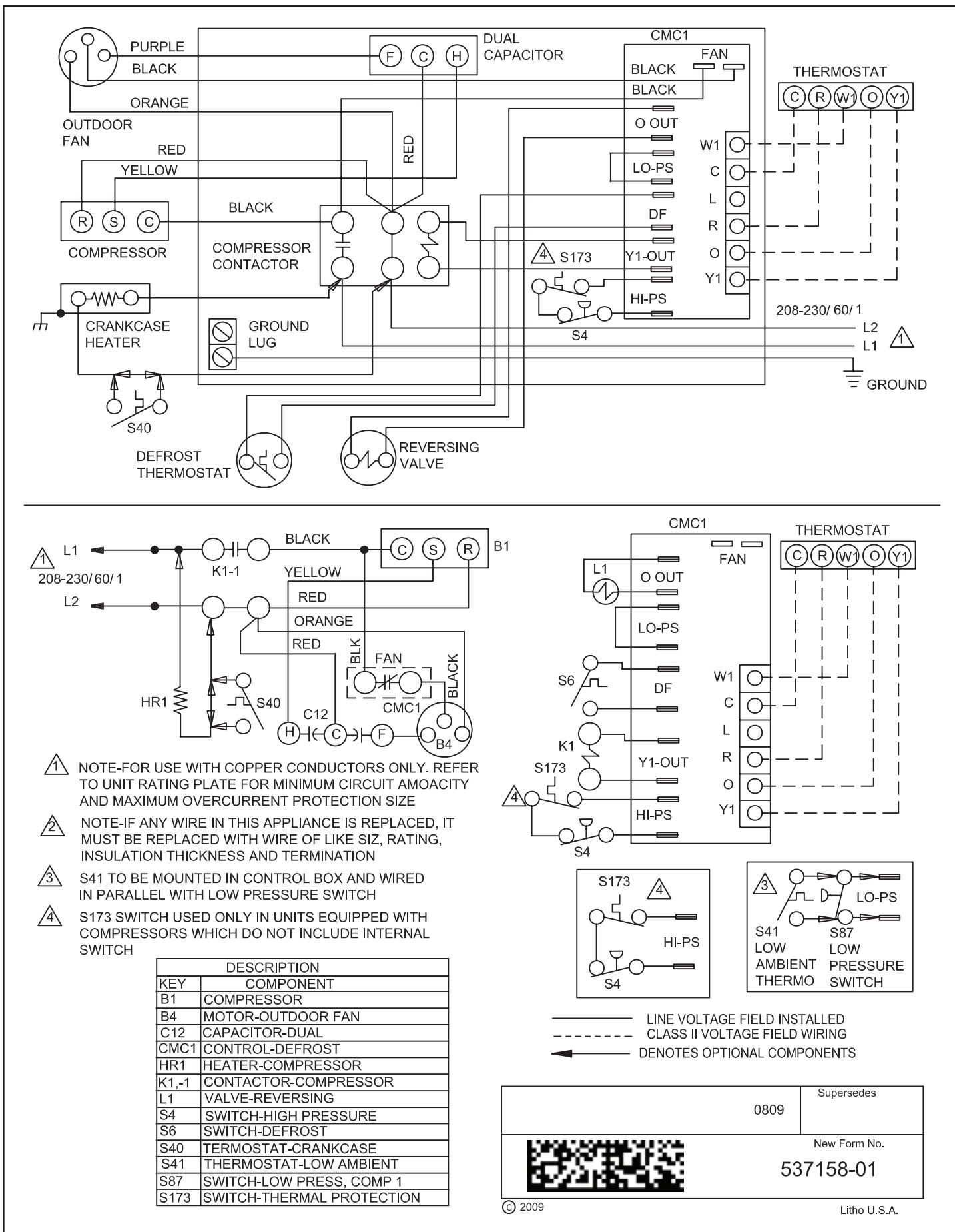

Figure 10. 14/15 SEER Wiring Diagram

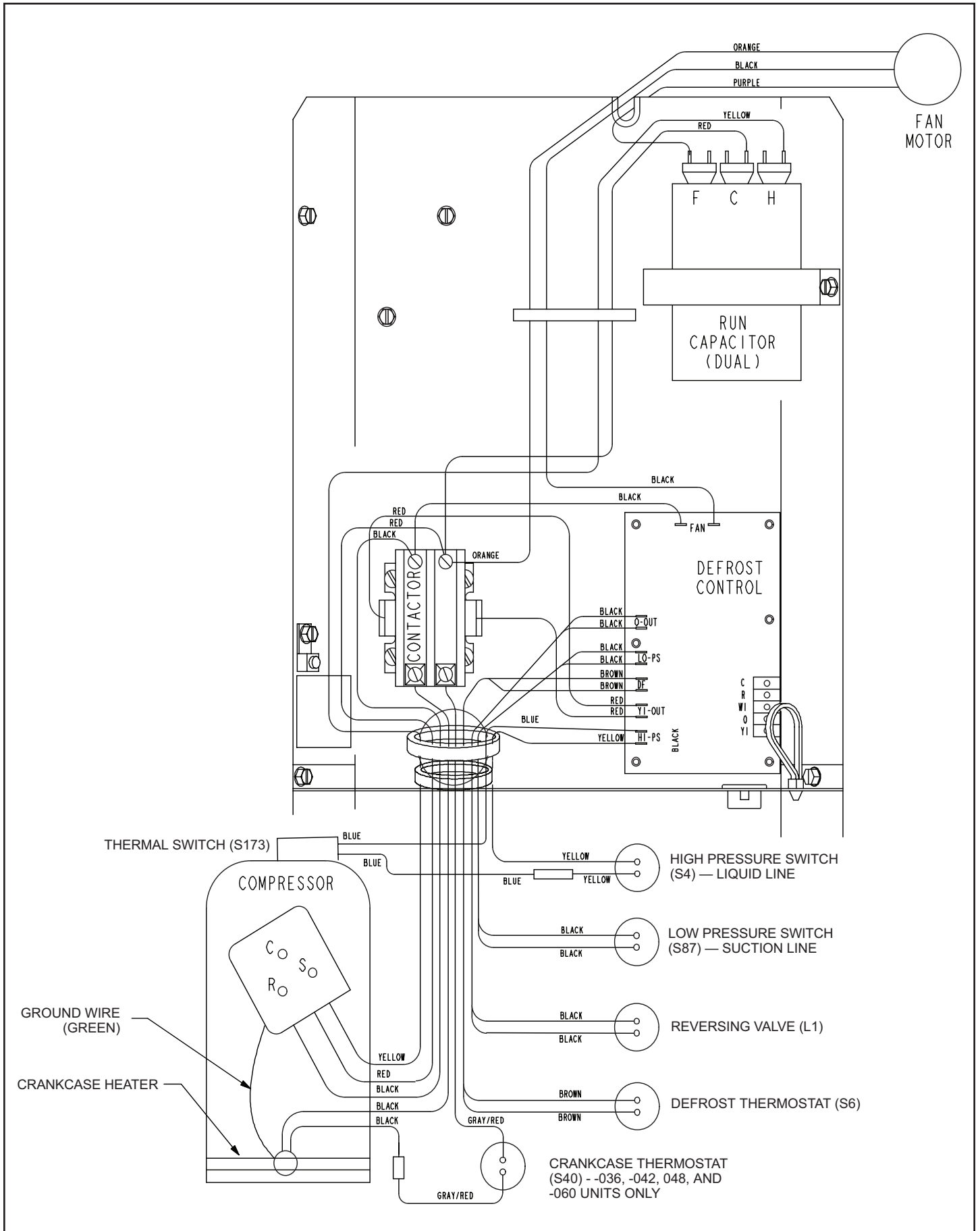

Figure 11. Typical Unit Factory Wiring

Start-Up

CAUTION

If unit is equipped with a crankcase heater, it should be energized 24 hours before unit start-up to prevent compressor damage as a result of slugging.

1. Rotate fan to check for frozen bearings or binding.
2. Inspect all factory and field-installed wiring for loose connections.
3. After evacuation is complete, open liquid line and suction line service valves to release refrigerant charge (contained in outdoor unit) into system.
4. Replace the stem caps and secure finger tight, then tighten an additional 1/6 of a turn.
5. Check voltage supply at the disconnect switch. The voltage must be within the range listed on the unit nameplate. If not, do not start equipment until the power company has been consulted and the voltage condition corrected.
6. Set thermostat for cooling demand, turn on power to indoor blower, and close the outdoor unit disconnect switch to start the unit.
7. Recheck unit voltage with unit running. Power must be within range shown on unit nameplate.

Refrigerant Charging

CAUTION

Excessive amounts of liquid refrigerant entering the suction line can damage the compressor. When adding refrigerant, precautions must be taken to control the flow of liquid into the system. This can be done by using a liquid vaporizing adapter or manual control using a sight glass as indicator.

Units are factory charged with the amount of R-410A refrigerant indicated on the unit rating plate. This charge is based on a matching indoor coil and outdoor coil with 15' line set. For varying lengths of line set, refer to Table 5 for refrigerant charge adjustment. A blank space is provided on the unit rating plate to list the actual field charge.

Liquid Line Set Diameter	Oz. Per 5 ft. adjust from 15 ft. line set*
3/8 in.	3 oz. per 5 ft. or 0.6 oz. per 1 ft.
* If line length is greater than 15 ft., add this amount. If line length is less than 15 ft., remove this amount.	

Table 5. Refrigerant Charge Adjustment

IMPORTANT

Mineral oils are not compatible with R-410A. If oil must be added, it must be a polyolester oil.

NOTE: Both airflow and refrigerant charge must be monitored for proper system set-up. It may be necessary to alternately check and adjust the airflow and the refrigerant charge.

If the system is void of refrigerant, or if the outdoor ambient temperature is cool, use the weigh-in method to charge the unit. Do this after any leaks have been repaired.

1. Recover the refrigerant from the unit.
2. Conduct a leak check, then evacuate as previously outlined.
3. Weigh in the charge according to the total amount shown on the unit nameplate.

If weighing facilities are not available or if unit is being charged during warm weather, use one of the following procedures.

- **For systems using a TXV on the indoor evaporator and outdoor temperature above 60°F** – charge in cooling mode using the subcooling method and table provided on the unit access panel.
- **For systems below 60°F** – charge in heating mode using the subcooling method and table provided on the unit access panel. Attach low pressure gauge hose to auxiliary service port to access suction side in heating mode.

NOTE: All unit table values are based on 70 to 80°F indoor return air temperature for cooling mode, and 65°F to 75°F return air temperature for heat mode.

GAUGE SET

CONNECTIONS FOR OPTIMIZING SYSTEM CHARGE

NOTE — Refrigerant tank should be turned right-side-up to deliver vapor during charge optimizing procedure.

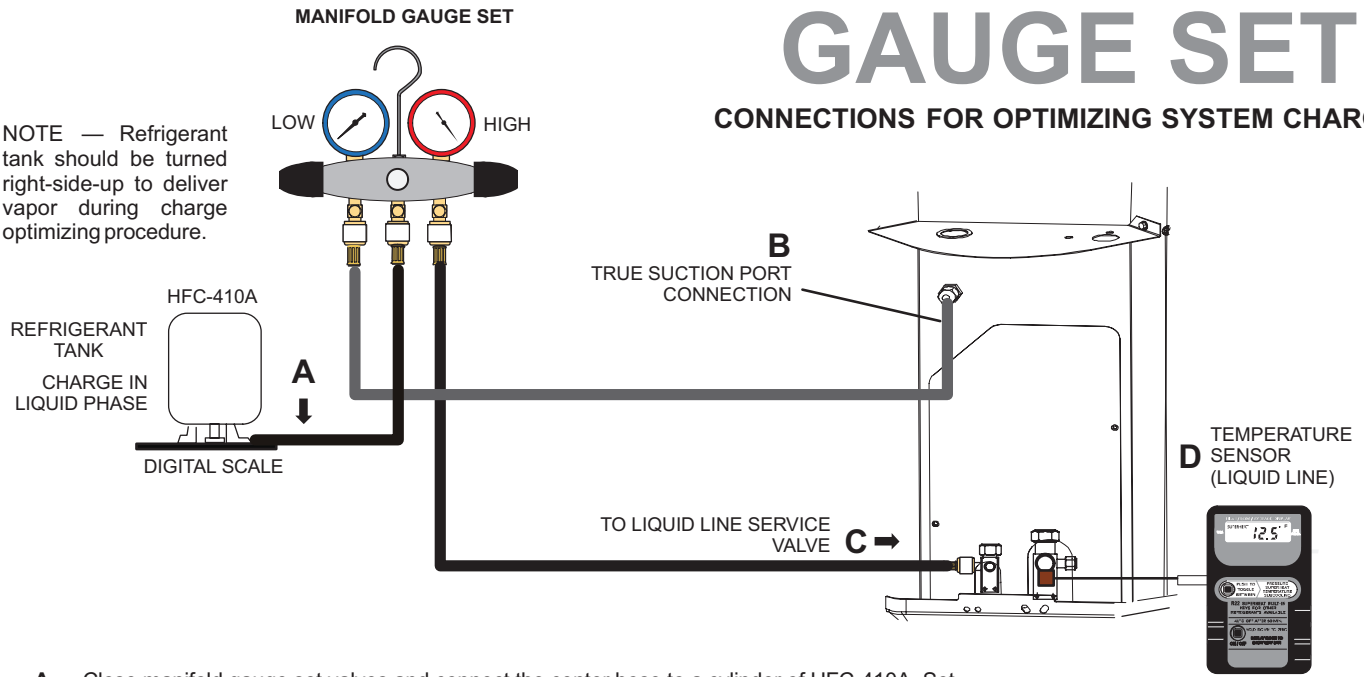

- A Close manifold gauge set valves and connect the center hose to a cylinder of HFC-410A. Set for liquid phase charging.
- B Connect the manifold gauge set's low pressure side to the true suction port.
- C Connect the manifold gauge set's high pressure side to the liquid line service port.
- D Position temperature sensor on liquid line near liquid line service port (use only for subcooling method).

NOTE — For simplify the illustration, the line set is not shown connected to service valves.

Figure 12. Gauge Set Connections

Use WEIGH IN method for adding initial refrigerant charge, and then use SUBCOOLING method for verifying refrigerant charge.

WEIGH IN

If the system is void of refrigerant, first, locate and repair any leaks and then weigh in the refrigerant charge into the unit. To calculate the total refrigerant charge:

Amount specified on nameplate

CALCULATING SYSTEM CHARGE FOR OUTDOOR UNIT VOID OF CHARGE

Adjust amount. for variation in line set length listed on line set length table below.

Additional charge specified per indoor unit match-ups (see applicable charging sticker)

Total charge

$$\underline{\hspace{2cm}} \quad + \quad \underline{\hspace{2cm}} \quad + \quad \underline{\hspace{2cm}} \quad = \quad \underline{\hspace{2cm}}$$

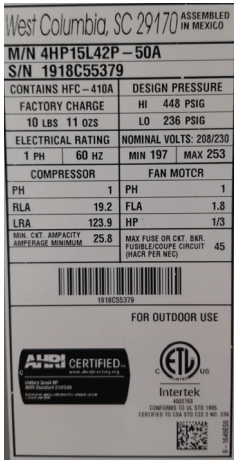

Refrigerant Charge per Line Set Length

Liquid Line Set Diameter	Ounces per 5 feet (g per 1.5 m) adjust from 15 feet (4.6 m) line set*
3/8" (9.5 mm)	3 ounce per 5' (85 g per 1.5 m)

*If line length is greater than 15 ft. (4.6 m), add this amount. If line length is less than 15 ft. (4.6 m), subtract this amount.

NOTE — Insulate liquid line when it is routed through areas where the surrounding ambient temperature could become higher than the temperature of the liquid line or when pressure drop is equal to or greater than 20 psig.

NOTE — The above nameplate is for illustration purposes only. Go to actual nameplate on outdoor unit for charge information.

Figure 14. Weigh In Method

SUBCOOLING

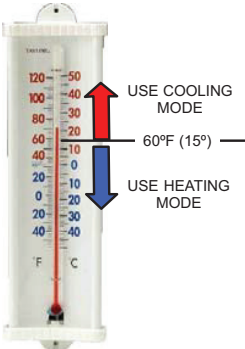

SAT° _____

LIQ° - _____

SC° = _____

- 1 Check the airflow as illustrated in figure 25 to be sure the indoor airflow is as required. (Make any air flow adjustments before continuing with the following procedure.)
- 2 Measure outdoor ambient temperature; determine whether to use **cooling mode** or **heating mode** to check charge.
- 3 Connect gauge set.
- 4 Check Liquid and Vapor line pressures. Compare pressures with Normal Operating Pressures on applicable charging sticker. *(The reference table is a general guide. Expect minor pressure variations. Significant differences may mean improper charge or other system problem.)*
- 5 Set thermostat for heat/cool demand, depending on mode being used:

Using cooling mode—When the outdoor ambient temperature is 60°F (15°C) and above. Target subcooling values in table below are based on 70 to 80°F (21-27°C) indoor return air temperature; if necessary, operate heating to reach that temperature range; then set thermostat to cooling mode setpoint to 68°F (20°C). When pressures have stabilized, continue with step 6.

Using heating mode—When the outdoor ambient temperature is below 60°F (15°C). Target subcooling values in table below are based on 65-75°F (18-24°C) indoor return air temperature; if necessary, operate cooling to reach that temperature range; then set thermostat to heating mode setpoint to 77°F (25°C). When pressures have stabilized, continue with step 6.
- 6 Read the liquid line temperature; record in the LIQ° space.
- 7 Read the liquid line pressure; then find its corresponding temperature in the temperature/ pressure chart listed in table 8 and record it in the SAT° space.
- 8 Subtract LIQ° temp. from SAT° temp. to determine subcooling; record it in SC° space.
- 9 Compare SC° results with table below, being sure to note any additional charge for line set and/or match-up.
- 10 If subcooling value is greater than shown on applicable charging sticker for the unit, remove refrigerant; if less than shown, add refrigerant.
- 11 If refrigerant is added or removed, repeat steps 5 through 10 to verify charge.

Figure 15. Subcooling Method

°F	°C	Psig	°F	°C	Psig
-40	-40.0	11.6	60	15.6	170
-35	-37.2	14.9	65	18.3	185
-30	-34.4	18.5	70	21.1	201
-25	-31.7	22.5	75	23.9	217
-20	-28.9	26.9	80	26.7	235
-15	-26.1	31.7	85	29.4	254
-10	-23.3	36.8	90	32.2	274
-5	-20.6	42.5	95	35.0	295
0	-17.8	48.6	100	37.8	317
5	-15.0	55.2	105	40.6	340
10	-12.2	62.3	110	43.3	365
15	-9.4	70.0	115	46.1	391
20	-6.7	78.3	120	48.9	418
25	-3.9	87.3	125	51.7	446
30	-1.1	96.8	130	54.4	476
35	1.7	107	135	57.2	507
40	4.4	118	140	60.0	539
45	7.2	130	145	62.8	573
50	10.0	142	150	65.6	608
55	12.8	155			

Table 6. HFC-410A Temperature — Pressure (Psig)

HFC-410A CHARGING INFORMATION – FOR COMPLETE CHARGING DETAILS, REFER TO THE OUTDOOR UNIT INSTALLATION INSTRUCTIONS

Maintenance checks using the Normal Operating Pressures table

Table 1 may be used to help perform maintenance checks. This table is not a procedure for charging the system and any minor variations in the pressures may be expected due to differences in installations. However, significant deviations could mean that the system is not properly charged or that a problem exists with some component in the system.

Charge Using the Subcooling Method (TXV Systems)

Cooling Mode – When the outdoor ambient temperature is 60°F (15°C) and above, use the cooling mode to adjust the charge using the subcooling method. Target subcooling values in table 2 are based on 70 to 80°F (21-27°C) indoor return air temperature.

Heating Mode – When the outdoor ambient temperature is below 60°F (15°C), use the heating mode to adjust the charge using the subcooling charge levels. Target subcooling values in table 2 are based on 65-75°F (18-24°C) indoor return air temperature.

Matchups/Charge Levels and Line Set Lengths

Table 2 lists all the recommended indoor unit matchups along with the charge levels for the various sizes of outdoor units. **Charge levels on the unit nameplate are based on installations with 15ft. (4.6m) line sets; on line sets with 3/8in. (9.5mm) liquid line, add 0.6oz additional refrigerant for every 1ft. (0.3m), longer than 15ft. If line length is less than 15ft., subtract this amount (see Installation Instructions for more details).**

Charge Using the Weigh-in Method

If the system is void of refrigerant, locate and repair any leaks, evacuate system, and then weigh in the refrigerant charge into the unit. For charge adjustments, be sure to consider line set length differences and, referring to table 1, adjust for the matchup difference.

- 1 - Recover the refrigerant from the unit.
- 2 - Conduct leak check; evacuate as previously outlined.
- 3 - Weigh in the unit nameplate charge, adjusting for matchup and line set length differences. If weighing facilities are not available use the Subcooling method.

Table 1 – Normal Operating Pressures (Liquid ±10 and Suction ±5 psig)

°F*	Heating Mode					Cooling Mode					
	20	30	40	50	60	65	75	85	95	105	115
SIZE	VAP/LIQ	VAP/LIQ	VAP/LIQ	VAP/LIQ	VAP/LIQ	VAP/LIQ	VAP/LIQ	VAP/LIQ	VAP/LIQ	VAP/LIQ	VAP/LIQ
-018	277/69	292/84	309/101	324/119	341/139	226/145	262/147	303/150	348/152	400/154	455/157
-024	281/65	294/80	308/95	319/113	335/130	234/142	271/145	315/146	362/149	415/151	473/152
-030	276/53	287/76	301/92	315/108	329/126	238/140	273/143	319/145	369/147	419/150	475/151
-036	279/61	292/71	307/85	328/109	344/128	228/139	265/141	307/144	353/147	404/150	461/151
-042	320/65	342/78	354/95	376/110	402/127	227/134	261/137	305/140	352/142	403/145	462/147
-048	322/63	340/75	349/85	357/96	400/124	230/129	267/132	310/136	356/139	409/142	466/144
-060	311/62	324/68	339/82	371/105	391/122	231/126	262/131	308/135	354/138	404/140	461/143

*Temperature of air entering the outdoor coil.

The values in this table are most popular match-up pressures; indoor match-up, indoor air quantity, and indoor load will cause the pressures to vary.



Figure 16. Charging Procedure HRG14

Start-Up and Performance Checklist

Job Name _____ Job no. _____ Date _____		
Job Location _____ City _____ State _____		
Installer _____ City _____ State _____		
Unit Model No. _____ Serial No. _____ Service Technician _____		
Nameplate Voltage _____		
Rated Load Ampacity _____ Compressor _____ Outdoor Fan _____		
Maximum Fuse or Circuit Breaker _____		
Electrical Connections Tight? <input type="checkbox"/>	Indoor Filter Clean? <input type="checkbox"/>	Supply Voltage (Unit Off) _____
Indoor Blower RPM _____	S.P. Drop Over Indoor (Dry) _____	Outdoor Coil Entering Air Temp. _____
Discharge Pressure _____	Vapor Pressure _____	Refrigerant Charge Checked? <input type="checkbox"/>
Refrigerant Lines: Leak Checked? <input type="checkbox"/>	Properly Insulated? <input type="checkbox"/>	Outdoor Fan Checked? <input type="checkbox"/>
Services Valve: Fully Opened? <input type="checkbox"/>	Caps Tight? <input type="checkbox"/>	Thermostat
Voltage with Compressor Operating _____	Calibrated? <input type="checkbox"/>	Properly Set? <input type="checkbox"/> Level? <input type="checkbox"/>